

2020 FULL LINE CATALOG





HANDCRAFTED QUALITY

INNOVATIVE, CREATIVE & DIFFERENT

Established in 1994, Ortega Guitars introduced German design to authentic and traditional methods of guitar making. Committed to innovation and quality, we strive to improve what is expected at every level of all our acoustic instruments. Options like the 12hole bridge, often found only on high-end guitars, are standard on our entry level to professional nylon string guitars. Our wide variety of body and neck sizes accommodates all ages giving everyone an opportunity to learn and play.

2020 FULL LINE CATALOG

INDEX

KEIKI	4	ACOUSTIC BASSES	58
UKULELES	5	Deep Traveler Series	59
K1 Ukuleles	5	Deep Series	60
K2 Ukulele Packs	6	MANDOLINS & BANJOS	62
ACCESSORIES	8	Mandolins	62
Picks	8	Banjos – Raven Series	64
Straps	9	Banjos – Falcon Series	65
Ukulele Bags	9	AMPLIFICATION SERIES	66
ORTEGA	10	STOMP BOX EFFECT SERIES	68
UKULELES OVERVIEW	11	PERCUSSION SERIES	70
Bonfire Series	14	ACCESSORIES OVERVIEW	72
Earth Series	16	Capos	74
Horizon Series	18	Vegan Straps & Accessories	76
Timber Series	19	Straps	77
Prism Series	22	Tuners	81
Lizard Series	22	Digital Wireless System	82
Banjolele Series	23	Cables	84
Custom Built Series	24	Strings	86
UKEBASSES	26	Picks	88
Lizard Series	27	Strap Locks & Tuning Machines	90
NYLON STRING GUITARS OVERVIEW	29	Cables & Power	92
Student Series	30	Preamps & Pickups	93
Family Series	32	Useful Helpers	94
Family Series Pro	38	Care	96
Performer Series	40	Humidifiers	97
Traveler Series	43	Bags	98
Traditional Series	44	Cases	101
Custom Master Selection Series	48	Stands & Hangers	104
Signature Series	50	POS	106
THE PRIVATE ROOM	54		
Distressed Suites	55		
Eclipse Suite	56		
Honey Suite	56		
Striped Suites	57		



Keiki®

Keiki® UKULELES

DESIGNED IN GERMANY BY ORTEGA®



K1-BL
Sopranino

	scale	width at nut
Sopranino	284 mm (11.18")	32 mm (1.26")

8
exciting
COLORS



K1-GR **K1-RD** **K1-CO**



K1-MM **K1-ORG**



K1-PNK **K1-PUR**

- Laser engraved sea turtle
- Okoume top satin, open pore
- Okoume back & side, satin open pore
- Keiki® headstock design w/ laser logo
- Okoume neck & headstock veneer, satin finish
- Walnut fretboard & bridge

- Open gear tuning machines chrome w/ black buttons
- Ortega Guitars UWNY-4-SO strings
- Available COLORS:

BL - ocean blue	MM - natural mahogany
GR - forest green	ORG - orange
RD - fire red	PNK - pink
CO - coal	PUR - purple



Keiki® UKULELE PACK

UNIQUE DESIGNS – CREATED BY ITALIAN STREET ARTIST GUGLIELMO GASLOLI

Guglielmo Gasloli – Graphic designer – Visual artist

An Italian artist trained in the environment of street art, his style is characterized by a horror-vacui of subjects elaborated by his personal "flow of conscience". His style is rich in colors, geometries, and attention to detail.

"THE IDEA DOES NOT HAVE TO BE CONVENTIONAL".

www.gasliartworks.com



K2 UKULELE PACK INCLUDES:

- Keiki® Headstock tuner
- Keiki® Soundhole hook strap/support
- Keiki® medium picks (5 piece)
- Keiki® Drawstring bag

K2
Ukulele Pack



spaceman

el muerto

peace '68

totem

samurai

voodoo puppet

K2
Ukulele Pack



K2-TM
Soprano
PACK



K2-SP
PACK



K2-EM
PACK



K2-68
PACK



K2-SR
PACK



K2-VP
PACK

	scale	width at nut
Soprano	364 mm (14.33")	36 mm (1.42")

- Agathis top, custom designed
- ABS body, slightly arched
- Keiki® headstock design w/ custom designed veneer
- Okoume neck, satin finish
- ABS fretboard & bridge
- Open gear tuning machines chrome w/ black buttons

- Ortega Guitars UWNY-4-SO strings
- Headstock tuner, Soundhole hook strap/support, 5 medium picks and drawstring bag included!
- Available PACKS/DESIGNS:

K2-SP - spaceman	K2-EM - el muerto
K2-68 - peace '68	K2-TM - totem
K2-SR - samurai	K2-VP - voodoo puppet



Keiki® PICKS



KPSP-5



KPEM-5



KP68-5



KPTM-5



KPSR-5



KPVP-5



KPSD-150



KPSP-25RF

each Series
5x5

KPEM-25RF

KP68-25RF

KPVP-25RF

KPTM-25RF

KPSR-25RF

KEIKI® DESIGNER PICKS

5 PICKS – 5 DIFFERENT DESIGNS

Keiki® designer picks are made of high quality celluloid, medium 0.71 mm, with a glossy surface.

- KPSP-5** spaceman
- KPEM-5** el muerto
- KP68-5** peace '68
- KPTM-5** totem
- KPSR-5** samurai
- KPVP-5** voodoo puppet

(5 slightly different designs in each series)

DISPLAY WITH 150 PICKS

Attractive, 100% recyclable hard paper sales display with 150x Keiki® designer picks included.

- KPSD-150** 25x KPSP-5 spaceman, 25x KPEM-5 el muerto, 25x KP68-5 peace '68, 25x KPTM-5 totem, 25x KPSR-5 samurai, 25x KPVP-5 voodoo puppet
- (5x5 slightly different designs in each series)

REFILL PACKS

Perfect to refill the KPSD-150 sales box or have safety stock in your pocket and for your fans. Each refill pack contains 25 picks (5x5 slightly different designs).

- KPSP-25RF** spaceman
- KPEM-25RF** el muerto
- KP68-25RF** peace '68
- KPTM-25RF** totem
- KPSR-25RF** samurai
- KPVP-25RF** voodoo puppet



KEIKI® DESIGNER UKULELE & GUITAR STRAPS

Made from strong but soft nylon and equipped with suede leather ends.
 Sizes: Ukulele 36 mm (1.42") width, up to 1440 mm (56.70") length / Guitar 50 mm (1.97") width, up to 1580 mm (62.20") length. Embossed logo on genuine leather badge.



UKULELES

KNS-SP-U
spaceman

KNS-EM-U
el muerto

KNS-68-U
peace '68

KNS-TM-U
totem

KNS-SR-U
samurai

KNS-VP-U
voodoo puppet



GUITARS

KNS-SP
spaceman

KNS-EM
el muerto

KNS-68
peace '68

KNS-TM
totem

KNS-SR
samurai

KNS-VP
voodoo puppet

Keiki® UKULELE BAGS

KEIKI® DESIGNER UKULELE BAGS

Professional ukulele bags – designed to be different and priced for any budget. Made from sturdy nylon material with a 10 mm soft inside padding. Includes an accessory compartment (fits an ORTEGA # OPUSxx portable uke stand) and two adjustable shoulder straps.

KUB-SP-xx spaceman

KUB-EM-xx el muerto

KUB-68-xx peace '68

KUB-TM-xx totem

KUB-SR-xx samurai

KUB-VP-xx voodoo puppet

Sizes: soprano (SO) – concert (CC) – tenor (TE)

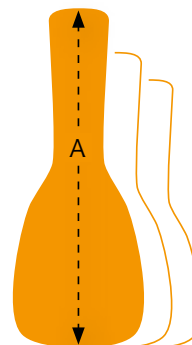

DIMENSIONS	
	A (inside)
soprano length	55.0 cm 21.65"
concert length	62.0 cm 24.41"
tenor length	68.0 cm 26.77"



photo: Givi Maghradze

ORTEGA[®]
GUITARS • EST 1994



UKULELES

OVERVIEW

BONFIRE SERIES

(see page 14)



EARTH SERIES

(see page 16)



HORIZON SERIES

(see page 18)



TIMBER SERIES

(see page 19)



PRISM SERIES

(see page 22)



LIZARD SERIES

(see page 22)



BANJOLELE SERIES

(see page 23)



CUSTOM BUILT SERIES

(see page 24)





ALL SERIES OPTIONS

scales and sizes

width at nut

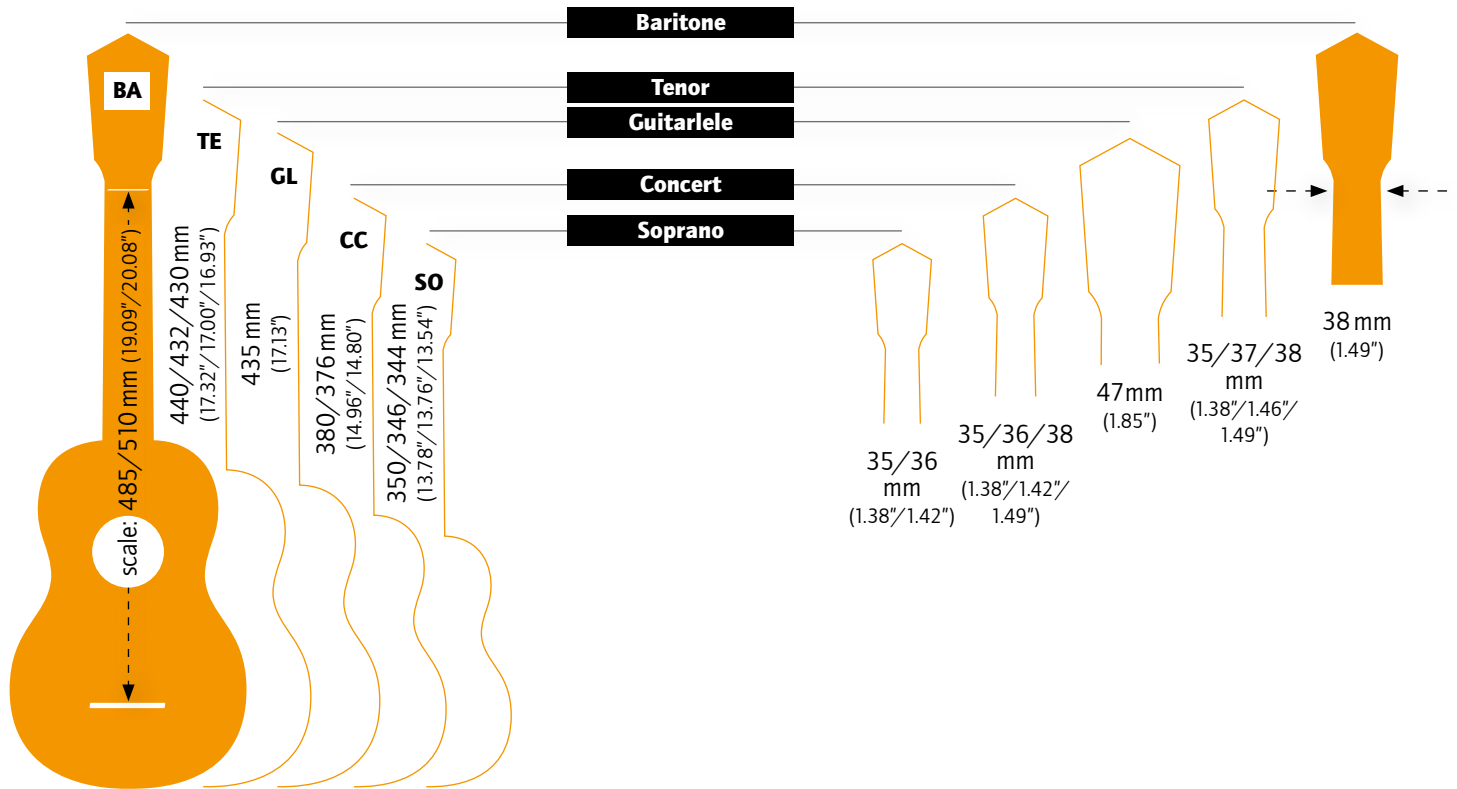

tuning

BA = D-G-B-E
 TE/CC/SO = G-C-E-A
 6string TE = G-Cc-E-Aa
 8string TE = Gg-Cc-EE-AA

strings



Ortega Guitars
 soprano UWN4-SO/
 concert UWN4-CC/
 tenor UWN4-TE/
 bariton UWN4-BA/
 tenor UNY-6-TE/
 tenor UNY-8-TE/
 guitarlele GLNY-6
 strings
 (see page 86)

electronics

**ORTEGA®
MagusUke**

Electronics w/ tuner
(see page 93)



Preamp with built-in tuner

**ORTEGA®
MagusUkeGO**

Electronics
(see page 93)



Plug in electronics
w/soundhole control



MagusUke electronics
are powered with
CR2032 coin cell
batteries
(see page 92)



features



bag



Preinstalled strap button
on all Ortega ukuleles

body



non
cutaway



cutaway

wood variations: back & sides

wood variations: top



solid mahogany sapele paldao (dao) acacia



spruce solid mahogany sapele zebrawood



walnut zebrawood okoume okoume



paldao (dao) acacia walnut okoume



okoume okoume okoume bamboo

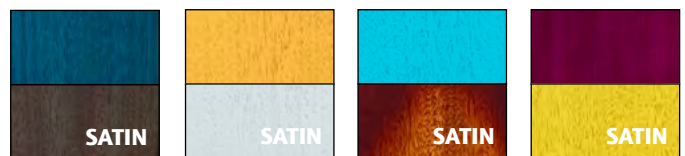

okoume okoume okoume okoume

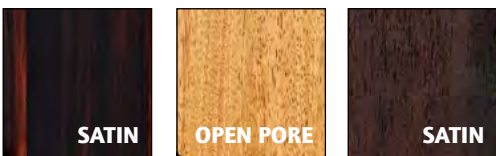

ebony mango ziricote

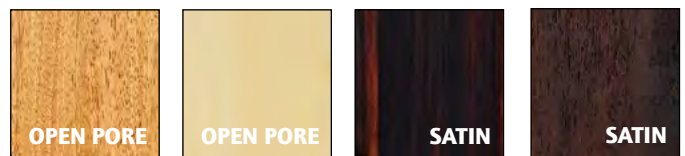

mango bamboo ebony ziricote





BONFIRE SERIES



ELECTRONICS W/ TUNER

ORTEGA
MagusUke

ORTEGA
MagusUkeGO



RU5-SO
Soprano

RU5CE-SO
Soprano



RU5
Concert

RU5CE
Concert



RU5L
Concert
LEFTHAND

RU5CE-L
Concert
LEFTHAND



RUPA5
Concert

RU5-TE
Tenor

RU5CE-TE
Tenor



RU5-BA
Baritone

RU5CE-BA
Baritone



- Spruce top, satin finish, laser engraved motif
- Sapele back & side, satin finish
- Mahogany neck, satin finish
- Tortoise style ABS binding
- Walnut fretboard & bridge

- Ortega MagusUke electronics w/ tuner (RU5CE-L: Ortega MagusUkeGO electronics)
- Die cast tuning machines, chrome w/ black buttons
- Ortega Guitars UWNY-4-SO/-CC/-TE/-BA strings

	scale	width at nut
Soprano	350 mm (13.78")	36 mm (1.42")
Concert	380 mm (14.96")	36 mm (1.42")
Tenor	440 mm (17.32")	37 mm (1.45")
Baritone	485 mm (19.09")	38 mm (1.49")

with EQ ELECTRONICS W/ TUNER
ORTEGA
 MagusUke



RGL5
Guitarlele



RGL5C
Guitarlele



RGL5CE **with EQ**
Guitarlele

- Spruce top, satin finish, laser engraved motif
- Mahogany back & side, satin finish
- Mahogany neck, satin finish
- 18 frets
- Ortega MagusUke electronics w/ tuner (RGL5CE)
- Walnut fretboard & bridge
- Ortega GLNY-6 strings

	scale	width at nut
Guitarleles	435 mm (17.13")	47 mm (1.85")

with EQ PLUG IN ELECTRONICS
 W/ SOUNDHOLE CONTROL
 PICKUP BUILT-IN



RU5MM-SO
Soprano



RU5MM
Concert



RUPA5MM
Concert



RUPA5MM-E **with EQ**
Concert



RU5MM-TE
Tenor



RU5MM-BA
Baritone

- Sapele top, satin finish, laser engraved motif
- Sapele back & side, satin finish
- Mahogany neck, satin finish
- Tortoise style ABS binding
- Walnut fretboard & bridge
- Die cast tuning machines, chrome w/ black buttons
- Active soundhole electronics (RUPA5MM-E)
- Strap pin connector (RUPA5MM-E)
- Ortega Guitars UWNY-4-SO/-CC/-TE/-BA strings

	scale	width at nut
Soprano	350 mm (13.78")	36 mm (1.42")
Concert	380 mm (14.96")	36 mm (1.42")
Tenor	440 mm (17.32")	37 mm (1.46")
Baritone	485 mm (19.09")	38 mm (1.49")



EARTH SERIES

with EQ ELECTRONICS W/ TUNER
ORTEGA
MagusUke



RUDAWN
Concert



RUDAWN-CE



RUFOREST



RUFOREST-CE



RUOCEAN



RUOCEAN-CE



RUFIRE



RUFIRE-CE



RUCOAL



RUCOAL-CE

	scale	width at nut
Concert	380 mm (14.96")	36 mm (1.42")

- Okoume top, back & side, dawn sunburst (forest green, ocean blue, fire red, coal black, ruby raspberry, gold, silver, lagoon turquoise, sun yellow) satin finish
- Mahogany neck
- White ABS binding
- Walnut fretboard & bridge
- Ortega MagusUke electronics w/ tuner (-CE)
- Die cast tuning machines, chrome
- Ortega Guitars UWNY-4-CC strings



RURUBY



RURUBY-CE 



RUSUN



RUSUN-CE 



RUGOLD



RUSILVER



RULAGOON





HORIZON SERIES



RUHZ-SFG



RUHZ-SBK



RUHZ-MM

- Okoume (SFG, SBK) || Mahogany (MM) top, satin open pore finish
- Okoume (SFG, SBK) || Mahogany (MM) back & side, satin open pore finish
- Reversed headstock, 4 in line
- Okoume neck & headstock veneer, satin finish (SFG, SBK) || Okoume neck & Mahogany headstock veneer, satin finish (MM)
- Black ABS top, bottom & fretboard binding (SBK fretboard only)
- Tecwood fretboard & bridge
- Die cast tuning machines, black w/ black buttons
- Ortega Guitars UWNY-4-CC strings

	scale	width at nut
Concert	376 mm (14.80")	35 mm (1.38")

SFG = sea foam green
SBK = satin black
MM = natural mahogany



RUMG

RUMG-CE



RUBO

RUBO-CE



RUWN

RUWN-CE

- Mango (MG) || Bamboo (BO) || Walnut (WN) top, satin open pore finish
- Mango (MG) || Bamboo (BO) || Walnut (WN) back & side, satin open pore finish
- Reversed headstock, 4 in line
- Okoume neck, satin finish
- Walnut top, bottom & fretboard binding (MG, BO)
- Maple top, bottom & fretboard binding (WN)
- Tecwood fretboard & bridge
- Ortega MagusUke electronics w/ tuner (-CE)
- Die cast tuning machines, gold w/ black buttons
- Ortega Guitars UWNY-4-CC strings
- Deluxe gig bag included

	scale	width at nut
Concert	376 mm (14.80")	35 mm (1.38")

MG = Mango
BO = Bamboo
WN = Walnut

with EQ **ELECTRONICS W/ TUNER**
ORTEGA
 MagusUke



RFU10S
Soprano



RFU10SE 
Soprano



RFU11S
Concert



RFU11SE 
Concert



- Sapele top, satin finish
- Sapele back & side, satin finish
- Mahogany neck, satin finish
- Walnut fretboard & bridge
- Ortega MagusUke electronics w/ tuner (E)
- Die cast tuning machines, chrome w/ black buttons
- Ortega Guitars UWNY-4-SO/-CC strings
- Deluxe gig bag included

	scale	width at nut
Soprano	350 mm (13.78")	36 mm (1.42")
Concert	380 mm (14.96")	36 mm (1.42")



RFU10Z
Soprano



RFU10ZE 
Soprano



RFU11Z
Concert



RFU11ZE 
Concert



- Zebrawood top, satin finish
- Zebrawood back & side, satin finish
- Mahogany neck, satin finish
- Walnut fretboard & bridge
- Ortega MagusUke electronics w/ tuner (E)
- Die cast tuning machines, chrome w/ black buttons
- Ortega Guitars UWNY-4-SO/-CC strings
- Deluxe gig bag included

	scale	width at nut
Soprano	350 mm (13.78")	36 mm (1.42")
Concert	380 mm (14.96")	36 mm (1.42")



TIMBER SERIES

with EQ ELECTRONICS W/ TUNER
ORTEGA MagusUke



RUEB-SO
Soprano



RUEB-CC
Concert



RGL5EB
Guitarlele



RGL5EB-CE
Guitarlele

- Ebony top, satin open pore finish
- Ebony back & side, satin open pore finish
- Mahogany neck, satin finish
- Ebony headstock veneer
- Tortoise style binding & tortoise style rosette
- 18 frets (RGL)
- Walnut fretboard & bridge
- Ortega MagusUke electronics w/ tuner (RGL5EB-CE)
- Die cast tuning machines, gold w/ black buttons
- Ortega Guitars UWNY-4-SO/-CC strings (RUEB) || Ortega GLNY-6 Guitarlele strings (RGL)
- Deluxe gig bag included (RUEB-SO & RUEB-CC)

	scale	width at nut
Soprano	350 mm (13.78")	35 mm (1.38")
Concert	380 mm (14.96")	36 mm (1.42")
Guitarlele	435 mm (17.13")	47 mm (1.85")

SOLID TOP



RUTI-SO
Soprano



RUTI-CC
Concert



RUTI-TE
Tenor



- SOLID cedar top, satin finish
- Walnut back & side, satin finish
- Okoume neck, satin finish
- Walnut/maple body binding
- Walnut fretboard & bridge
- Maple "bar" fretboard inlays
- Walnut fretboard binding
- Classic headstock, Ovangkol veneer
- Bone nut & saddle
- Die cast tuning machines, gold w/ black buttons
- Ortega Guitars UWNY-4-SO/-CC/-TE strings
- Deluxe gig bag included

	scale	width at nut
Soprano	346 mm (13.62")	35 mm (1.38")
Concert	382 mm (15.04")	36 mm (1.42")
Tenor	432 mm (17.00")	37 mm (1.45")

TIMBER SERIES

**SOLID TOP & SOLID BACK,
OPEN PORE FINISH**



RUACA-SO
Soprano



RUACA-CC
Concert



RUACA-TE
Tenor



RUACA-BA
Baritone



	scale	width at nut
Soprano	344 mm (13.54")	35 mm (1.38")
Concert	376 mm (14.80")	35 mm (1.38")
Tenor	430 mm (16.93")	35 mm (1.38")
Baritone	510 mm (20.08")	38 mm (1.49")

- Solid acacia top, satin open pore finish
- Solid acacia back, satin open pore finish
- Acacia side, satin open pore finish
- Okoume neck, satin finish
- Padouk top, back & fretboard binding
- Tecwood fretboard & bridge
- Die cast tuning machines, gold w/ black buttons
- Ortega Guitars UWNY-4-SO/-CC/-TE/-BA strings
- Deluxe gig bag included

ALL SOLID MAHOGANY



RU10
Soprano



RU11
Concert



RGLE18FMH

ELECTRONICS W/ TUNER
ORTEGA
MagusUke



	scale	width at nut
Guitarleles	435 mm (17.13")	47 mm (1.85")

- Solid mahogany top, satin finish
- Solid mahogany back & side, satin finish
- Mahogany neck, satin finish
- Ivory ABS binding
- Walnut fretboard & bridge
- Open gear tuning machines, gold w/ white buttons
- Ortega Guitars UWNY-4-SO/-CC strings
- Deluxe gig bag included

- Flamed mahogany top, gloss finish
- Flamed mahogany back & side, gloss finish
- Mahogany neck, satin finish
- 18 frets
- Ortega MagusUke electronics w/ tuner
- Walnut fretboard & bridge
- Ortega GLNY-6 strings
- Deluxe gig bag included



PRISM SERIES



RUPR-TRI



RUPR-TQB



RUPR-IVY



- Flamed maple top, transparent color fade, gloss finish
- Flamed maple back & side, transparent color fade, gloss finish
- Maple neck, transparent color fade, gloss finish
- Maple (TRI, TQB) || Walnut (IVY) fretboard, fretboard binding & bridge
- Slotted headstock, flamed maple veneer
- Walnut binding & Abalone style purfling & rosette, transparent color fade, gloss finish
- Bone nut & saddle
- Single tuning machines, gold w/ gold buttons
- Ortega Guitars UWN4-4TE strings
- Deluxe gig bag included

	scale	width at nut
Tenor	432 mm (17.00")	37 mm (1.49")

TRI = tri color fade
TQB = tequila burst fade
IVY = ivy fade

LIZARD SERIES

 **ELECTRONICS W/ TUNER**
ORTEGA
 MagusUke



LIZARD-SO-GB 
Soprano



LIZARD-CC-GB 
Concert



LIZARD-TE-GB 
Tenor



- Paldao top, satin finish
- Paldao back & side, satin finish
- Mahogany neck, gloss finish
- Walnut binding
- Walnut fretboard & bridge
- Maple Lizard fretboard inlay
- Ortega MagusUke electronics w/ tuner
- Die cast tuning machines, gold w/ gold buttons
- Ortega Guitars UWN4-4-SO/-CC/-TE strings
- Deluxe gig bag included

	scale	width at nut
Soprano	346 mm (13.76")	35 mm (1.38")
Concert	380 mm (14.96")	36 mm (1.42")
Tenor	432 mm (17.00")	37 mm (1.45")

OUBJ100-SBK



scale: 394 mm (15.51")
width at nut: 35 mm (1.38")



- 4string Banjo
- Hard maple neck, satin black finish
- Maple ply body, open back, satin black finish
- Ovangkol fretboard
- 18 brackets
- Chrome hardware
- Remo ebony head, black
- Open gear tuning machines
- Ortega UWNY-4-CC strings
- Deluxe Banjo bag included

BUILT-IN PICKUP SYSTEM



scale: 394 mm (15.51")
width at nut: 35 mm (1.38")

OUBJE90-MA



- 4string Banjo
- Hard maple neck, natural
- Maple body, open back
- Maple fretboard w/ black ABS binding
- 12 brackets, brushed brass
- Remo head, coated
- Open gear brushed brass tuning machines
- Passive transducer pickup system built-in
- Ortega UWNY-4-CC strings
- Deluxe Banjo bag included





CUSTOM BUILT SERIES ALL SOLID MAHOGANY

DOUBLE SOUNDHOLE
BUILT-IN ARMREST
ERGONOMIC CUTAWAY



ECLIPSE-CC4
Concert

ECLIPSE-TE6
Tenor

ECLIPSE-TE8
Tenor

- Solid Mahogany top, gloss finish
- Solid Mahogany back & side, gloss finish
- Solid Okoume neck, gloss finish
- Slotted headstock
- Walnut top, back & fretboard binding
- Walnut rear headstock veneer
- Walnut fretboard & bridge
- Eclipse fretboard inlays, custom made
- Additional side soundhole
- Bone nut & saddle
- Single tuning machines, gold w/ gold buttons || 6string tuning machines w/ toroise style buttons || 8string tuning machines w/ tortoise style buttons
- Ortega UWN4-CC/UNY-6-TE/ UNY-8-TE strings
- Deluxe gig bag included

	scale	width at nut
Concert	380 mm (14.96")	38 mm (1.49")
Tenor 6string	430 mm (16.93")	38 mm (1.49")
Tenor 8string	430 mm (16.93")	38 mm (1.49")

tuning:
CC/TE = G-C-E-A
6string TE = G-Cc-E-Aa
8string TE = Gg-Cc-EE-AA

with EQ ELECTRONICS W/ TUNER
ORTEGA
MagusUke



ARCHED TOP

Concert scale: 382 mm (15.04")
width at nut: 37 mm (1.46")

RUSL-HSB **with EQ**



- Flamed maple, arched top, satin finish
- Flamed maple arched back & side, satin finish
- Okoume neck, satin finish
- Walnut fretboard & Mandolin bridge
- Walnut fretboard binding
- Classic headstock, Ovangkol veneer
- F-holes
- Bone nut & saddle
- Die cast tuning machines, gold w/ black buttons
- Ortega MagusUke electronics w/ tuner
- Ortega Guitars UWN4-CC strings
- Deluxe gig bag included



DOUBLE NECK UKULELE 4/8string, Tenor

both necks
scale: 430 mm (16.93")
width at nut: 38 mm (1.49")

tuning:
TE = G-C-E-A
8string TE = Gg-Cc-EE-AA

HYDRA

- Ovangkol top, open pore satin finish
- Ovangkol back & side, open pore satin finish
- Mahogany necks, natural satin finish
- Tenor 8string & Tenor 4string
- Slotted headstocks
- Walnut armrest & fretboard binding
- Walnut fretboard & bridge
- Tortoise style body binding
- Bone nut & saddle
- Custom built electronics with 3way toggle switch (neck 8/both/neck 4)
- 8string tuning machines gold/gold & single tuning machines gold/gold (4string)
- Ortega Guitars Tenor UWNY-4-TE/ UWNY-8-TE strings
- Deluxe gig bag included



DOUBLE NECK UKULELE 4/8string, Tenor

both necks
scale: 430 mm (16.93")
width at nut: 38 mm (1.49")

tuning:
TE = G-C-E-A
8string TE = Gg-Cc-EE-AA

HYDRA-ZS

- Zircote top, open pore satin finish
- Zircote back & side, open pore satin finish
- Mahogany necks, natural satin finish
- Tenor 8string & Tenor 4string
- Slotted headstocks
- Walnut armrest
- Maple fretboards & bridges
- Mahogany body & fretboard binding
- Walnut "tree of life" fretboard inlay
- Bone nut & saddle
- Custom built electronics with 3way toggle switch (neck 8/both/neck 4)
- 8string tuning machines gold/gold & single tuning machines gold/gold (4string)
- Ortega Guitars Tenor UWNY-4-TE/ UWNY-8-TE strings
- Deluxe gig bag included





UKEBASSES



photo: René Anderl | Medienbeweger

OPTIONS

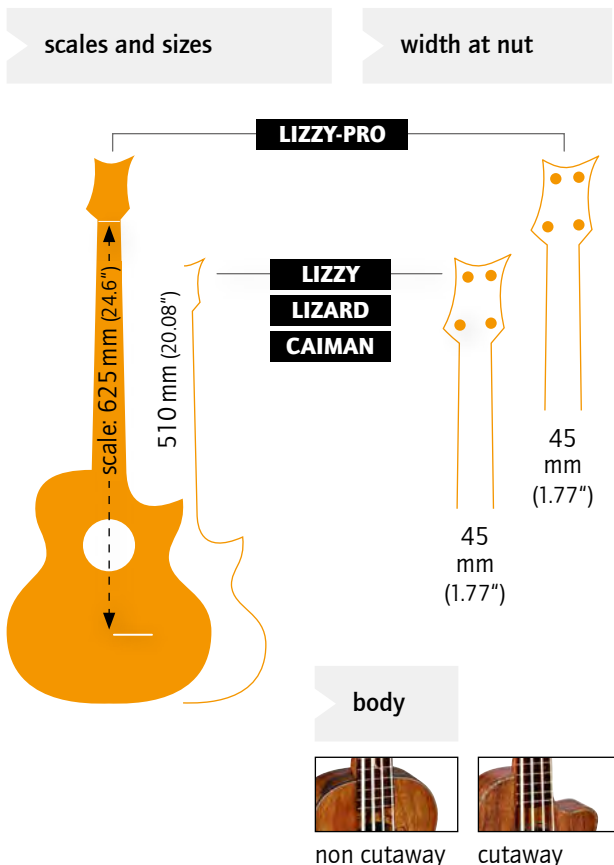

wood variations: top

SOLID

mahogany paldao (dao) acacia

wood variations: back & sides

mahogany paldao (dao) acacia

color/finish

natural NT:
satin finish/gloss finish

features



2way truss rod



bag

strings



Aquila Thundergut Ukebass long/short scale

electronics

ORTEGA®
MagusUkebass
Electronics w/ tuner (see page 93)



Ukebass scale: 510 mm (20.08")
 width at nut: 45 mm (1.77")

LIZZY-BS-GB with EQ

LIZZY-BSFL-GB with EQ
LINED FRETLESS

- Mahogany top, satin finish
- Mahogany back & side, satin finish
- Mahogany neck, satin finish
- Walnut fretboard & bridge
- Black ABS binding/white purfling
- Ortega MagusUkeBass electronics w/ tuner
- 15 frets
- 2way truss rod
- Aquila Thundergut Ukebass 68U strings, short scale
- Deluxe gig bag included



Longscale Ukebass scale: 625 mm (24.60")
 width at nut: 45 mm (1.77")

LIZZY-PRO with EQ
LINED FRETLESS

- SOLID mahogany top, satin finish
- Mahogany back & side, satin finish
- Mahogany neck, satin finish
- Pao Ferro fretboard & bridge
- Black ABS binding/white purfling
- Lasered Lizard rosette
- Ortega MagusUkeBass electronics w/ tuner
- 2way truss rod
- Aquila Thundergut Ukebass strings/ long scale
- Deluxe gig bag included



Ukebass scale: 510 mm (20.08")
 width at nut: 45 mm (1.77")

LIZARD-BS-GB with EQ

- Dao top, satin finish
- Dao back & side, satin finish
- Mahogany neck, satin finish
- Walnut fretboard & bridge
- Black ABS binding/white purfling
- Ortega MagusUkeBass electronics w/ tuner
- 15 frets
- 2way truss rod
- Aquila Thundergut Ukebass 68U strings, short scale
- Deluxe gig bag included



Ukebass **ARCHED BACK** scale: 510 mm (20.08")
 width at nut: 45 mm (1.77")

CAIMAN-BS-GB with EQ

CAIMAN-FL-GB with EQ
LINED FRETLESS

- Acacia top, gloss finish
- Acacia back (arched) & side, gloss finish
- Mahogany neck, gloss finish
- Walnut fretboard & bridge
- Mahogany body & fretboard binding
- Abalone style purfling
- Mahogany dot fretboard inlays
- Ortega MagusUkeBass electronics w/ tuner
- 2way truss rod
- Custom made indirect Ukebass tuning machines, black
- Aquila Thundergut Ukebass 68U strings, short scale
- Deluxe gig bag included





artist: Manith Bertz | photo: Anderl/Haas | Medienbeweger



Q **ORTEGA**[®]
GUITARS • EST 1994

NYLON STRING GUITARS

OVERVIEW

STUDENT SERIES

(see page 30)



FAMILY SERIES

(see page 32)



PERFORMER SERIES

(see page 40)



TRAVELER SERIES

(see page 43)



TRADITIONAL SERIES

(see page 44)



CUSTOM MASTER SERIES

(see page 48)



SIGNATURE SERIES

(see page 50)



THE PRIVATE ROOM

(see page 54)





STUDENT SERIES

OPTIONS





RST5-1/2
1/2 size



RST5-3/4
3/4 size



RST5
full size

- Spruce top, gloss finish
- Catalpa back & side, gloss finish
- ABS binding
- Mahogany neck, gloss finish
- Walnut fretboard & bridge
- Ortega 6hole bridge

	scale	width at nut
1/2 size	560 mm (22.05")	43.5 mm (1.71")
3/4 size	590 mm (23.23")	45 mm (1.77")
full size	650 mm (25.59")	52 mm (2.05")



RST5M
full size



RSTC5M
full size



RST5MBK
full size

- Spruce top (RST5M & RST5MBK) || Cedar top, matte satin finish (RSTC5M)
- Catalpa back & side
- Pinstripe rosette (RST5M & RST5MBK) || Classical rosette (RSTC5M)
- ABS binding
- Mahogany neck
- Walnut fretboard & bridge
- Ortega 6hole bridge

	scale	width at nut
full size	650 mm (25.59")	52 mm (2.05")

M = matte satin finish
MBK = matte satin finish black



FAMILY SERIES

OPTIONS

scales and sizes

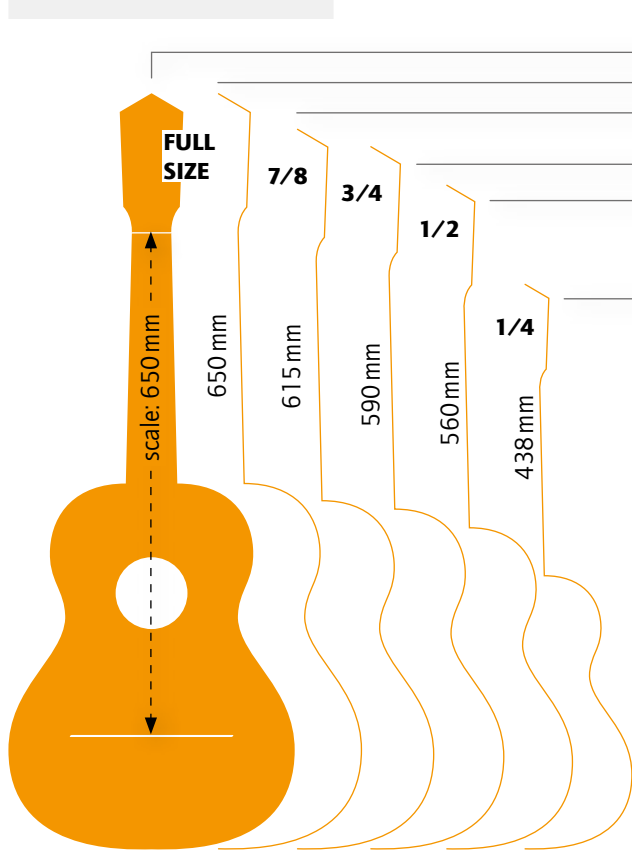

width at nut

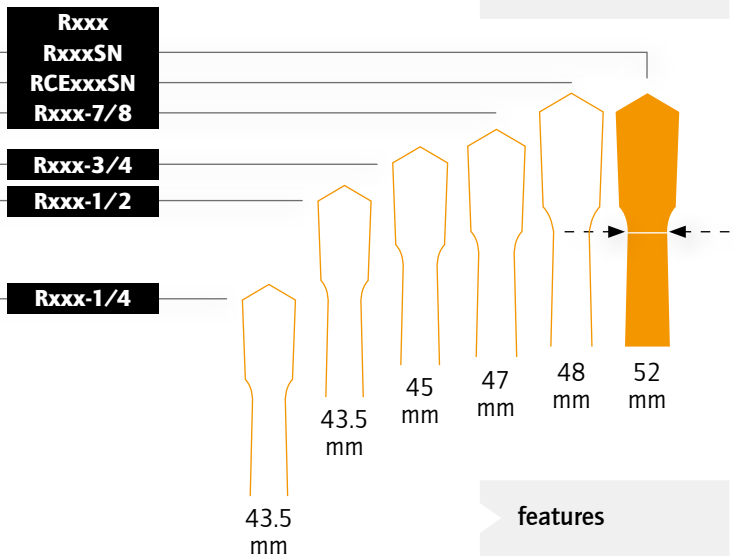

features

lefthand:
Rxxx **L**



12hole bridge



2way truss rod



bag

strings

SAVAREZ

510CJ (4/4 & 7/8 size)
540CS (3/4 size)
540CXS (1/2 & 1/4 size)

color/finish variations



natural NT:
satin finish



black BK:
gloss finish



black SBK:
satin finish



wine red WR:
gloss finish



white WH:
gloss finish

wood variations: top



spruce



cedar

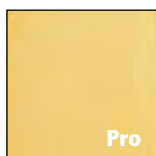

solid spruce



solid cedar

wood variations: back & sides



mahogany

body



non cutaway



cutaway

electronics:
RCExxx



ORTEGA
MagusPRO/G

Electronics
(see page 93)



R121-1/4
1/4 size



R121-1/2
1/2 size



R121-3/4
3/4 size



R121L-3/4
3/4 size
LEFTHAND



R121-7/8
7/8 size



R121
full size



R121L
full size
LEFTHAND



R121SN
full size
SLIM NECK



RCE125SN
full size
SLIM NECK
THINLINE BODY



RCE125SN-SBK
full size
SLIM NECK
THINLINE BODY

- Spruce top, satin finish || satin black finish (SBK)
- Mahogany back & side, satin finish || satin black finish (SBK)
- Mahogany neck, satin finish || satin black finish (SBK)
- Walnut fretboard & bridge || Walnut fretboard w/ white ABS binding, walnut bridge (SBK)
- Ortega MagusPro electronics w/ tuner (RCE)
- Ortega 12hole bridge
- 2way truss rod (1/2, 3/4, 7/8 & full size)
- Savarez strings 540CXS (1/4 & 1/2 size)/540CS (3/4 size)/510CJ (7/8 & full size)
- Deluxe gig bag included

	scale	width at nut
1/4 size	438 mm (17.24")	43.5 mm (1.71")
1/2 size	560 mm (22.05")	43.5 mm (1.71")
3/4 size	590 mm (23.23")	45 mm (1.77")
7/8 size	615 mm (24.21")	47 mm (1.85")
full size SN	650 mm (25.59")	48 mm (1.89")
full size	650 mm (25.59")	52 mm (2.05")

SBK = satin black



FAMILY SERIES CEDAR TOP



R122-1/4
1/4 size



R122-1/2
1/2 size



R122-3/4
3/4 size



R122L-3/4
3/4 size
LEFTHAND

+



R122-7/8
7/8 size



R122
full size



R122L
full size
LEFTHAND



R122SN
full size
SLIM NECK

- Cedar top, satin finish
- Mahogany back & side, satin finish
- Mahogany neck, satin finish
- Walnut fretboard & bridge
- Ortega 12hole bridge
- 2way truss rod (1/2, 3/4, 7/8 & full size)
- Savarez strings 540CXS (1/4 & 1/2 size)/540CS (3/4 size)/510CJ (7/8 & full size)
- Deluxe gig bag included

	scale	width at nut
1/4 size	438 mm (17.24")	43.5 mm (1.71")
1/2 size	560 mm (22.05")	43.5 mm (1.71")
3/4 size	590 mm (23.23")	45 mm (1.77")
7/8 size	615 mm (24.21")	47 mm (1.85")
full size SN	650 mm (25.59")	48 mm (1.89")
full size	650 mm (25.59")	52 mm (2.05")



R221BK-3/4
3/4 size

R221BK-7/8
7/8 size

R221SNBK
full size
SLIM NECK

R221BK
full size

- Spruce top, gloss finish black
- Mahogany back & side, gloss finish black
- Mahogany neck, gloss finish black
- Walnut fretboard & bridge
- Mahogany body & fretboard binding
- White abalone style purfling
- Ortega 12hole bridge
- 2way truss rod
- Savarez strings 540CS (3/4 size)/ 510CJ (7/8 & full size)
- Deluxe gig bag included

	scale	width at nut
3/4 size	590 mm (23.23")	45 mm (1.77")
7/8 size	615 mm (24.21")	47 mm (1.85")
full size SN	650 mm (25.59")	48 mm (1.89")
full size	650 mm (25.59")	52 mm (2.05")

BK = black





FAMILY SERIES SPRUCE TOP



R121-1/4WR
1/4 size



R121-1/2WR
1/2 size



R121-3/4WR
3/4 size



R121-7/8WR
7/8 size

+



R121WR
full size



R121LWR
full size
LEFTHAND



R121SNWR
full size
SLIM NECK

- Spruce top, gloss finish wine red
- Mahogany back & side, gloss finish wine red
- Mahogany neck, gloss finish wine red
- Walnut fretboard & bridge
- Ortega 12hole bridge
- 2way truss rod (1/2, 3/4, 7/8 & full size)
- Savarez strings 540CXS (1/4 & 1/2 size)/540CS (3/4 size)/510CJ (7/8 & full size)
- Deluxe gig bag included

	scale	width at nut
1/4 size	438 mm (17.24")	43.5 mm (1.71")
1/2 size	560 mm (22.05")	43.5 mm (1.71")
3/4 size	590 mm (23.23")	45 mm (1.77")
7/8 size	615 mm (24.21")	47 mm (1.85")
full size SN	650 mm (25.59")	48 mm (1.89")
full size	650 mm (25.59")	52 mm (2.05")

WR = wine red



R121-1/2WH
1/2 size

R121-3/4WH
3/4 size

R121-7/8WH
7/8 size



- Spruce top, gloss finish white
- Mahogany back & side, gloss finish white
- Mahogany neck, gloss finish white
- Walnut fretboard & bridge
- Ortega 12hole bridge
- 2way truss rod
- Savarez strings 540CXS (1/2 size)/540CS (3/4 size)/510CJ (7/8 & full size)
- Deluxe gig bag included



R121WH
full size

R121SNWH
full size
SLIM NECK

	scale	width at nut
1/2 size	560 mm (22.05")	43.5 mm (1.71")
3/4 size	590 mm (23.23")	45 mm (1.77")
7/8 size	615 mm (24.21")	47 mm (1.85")
full size SN	650 mm (25.59")	48 mm (1.89")
full size	650 mm (25.59")	52 mm (2.05")

WH = white

ACCESSORIES



OPGS-10RBK
PORTABLE GUITAR STAND
(see page 104)



OMS-1BK
MUSIC STAND
(see page 104)



FAMILY SERIES PRO SOLID CEDAR TOP

FULL SIZE



ELECTRONICS W/ TUNER

ORTEGA
MagusPRO/G



R131



RCE131



R131L

LEFTHAND



RCE131L

LEFTHAND



R131SN

SLIM NECK



RCE131SN

SLIM NECK



R131SN-WR

SLIM NECK

+



- Solid Canadian Western Red Cedar top, satin finish || gloss finish wine red (transparent)
- Mahogany back & side, satin finish || gloss finish wine red (transparent)
- Mahogany neck, satin finish || gloss finish wine red (transparent)
- Walnut fretboard & bridge

- Ortega MagusPro electronics w/ tuner (RCE131, RCE131L, RCE131SN)
- Ortega 12hole bridge
- 2way truss rod
- Savarez 510CJ strings
- Deluxe gig bag included

	scale	width at nut
full size SN	650 mm (25.59")	48 mm (1.89")
full size	650 mm (25.59")	52 mm (2.05")

WR = wine red

FAMILY SERIES PRO SOLID SPRUCE TOP

FULL SIZE



ELECTRONICS W/ TUNER

ORTEGA
MagusPRO/G



RCE141BK



RCE145BK



RCE145LBK



RCE145WH



SLIM NECK
THINLINE
BODY DEPTH

LEFTHAND
SLIM NECK
THINLINE
BODY DEPTH

SLIM NECK
THINLINE
BODY DEPTH

- Solid Canadian Engelmann spruce top, gloss finish black || gloss finish white
- Mahogany back & side, gloss finish black || gloss finish white
- Mahogany neck, gloss finish black || gloss finish white
- Walnut fretboard (flat) & bridge
- Ortega MagusPro electronics w/ tuner
- Ortega 12hole bridge
- 2way truss rod
- Savarez 510CJ strings
- Deluxe gig bag included

	scale	width at nut
full size SN	650 mm (25.59")	48 mm (1.89")
full size	650 mm (25.59")	52 mm (2.05")

BK = black
WH = white





PERFORMER SERIES

OPTIONS

scales and sizes

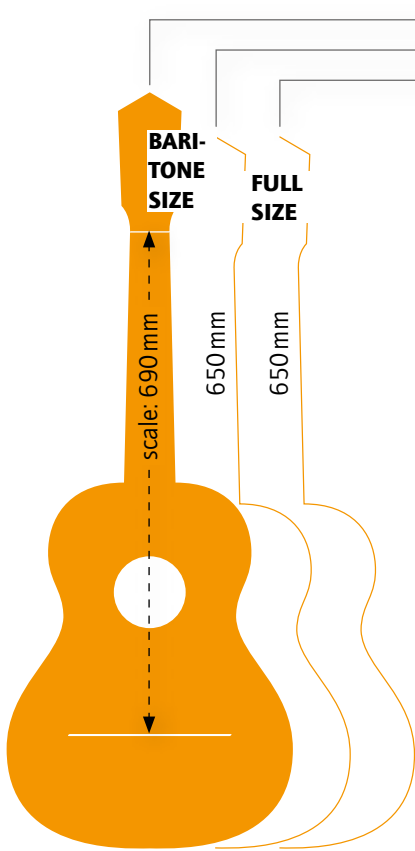

width at nut

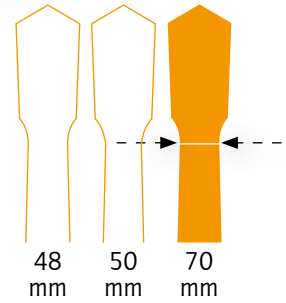

Rxxx-8
RxxxMN
RxxxSN

body



non cutaway



regular depth



cutaway



thinline

features



Spanish heel

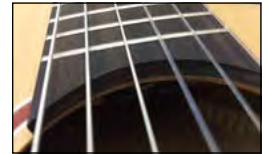

radiused fretboard



14th fret heel to body connection



12hole/16hole bridge



2way truss rod



bag

color/finish variations



natural NT:
gloss finish

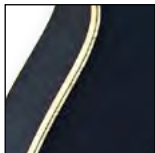

black BK:
gloss finish

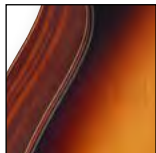

tobacco
sunburst TSB:
gloss finish
(top only)

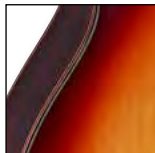

honey
burst HSB:
gloss finish
(top only)



stained red STR:
gloss finish



white WH:
gloss finish

lefthand: Rxxx L



strings

SAVAREZ

Savarez 500CJ strings

ORTEGA GUITARS
CUSTOM MADE STRINGS
8string

electronics: RCExxx



Preamp with
built-in tuner



wood variations: top



solid spruce



solid cedar



mahogany



walnut

wood variations: back & sides

PERFORMER SERIES SOLID SPRUCE TOP

SLIM NECK/SPANISH HEEL



ELECTRONICS W/ TUNER
ORTEGA
MagusPRO/G



RCE138SN



RCE138SN-L



LEFTHAND

+



	scale	width at nut
full size	650 mm (25.59")	48 mm (1.89")

- Solid Alaskan Sitka spruce top, gloss finish
- Sapele back & side, gloss finish
- Mahogany neck, gloss finish
- Indian Laurel fretboard & bridge
- Ortega MagusPro electronics w/ tuner
- Ortega 12hole bridge
- Ortega signature walnut/maple/white pearl rosette
- 2way truss rod
- Savarez 500CJ strings
- Deluxe gig bag included



RCE138-T4STR



THINLINE
BODY DEPTH



RCE138-T4BK



THINLINE
BODY DEPTH



RCE138-T4BK-L



LEFTHAND
THINLINE
BODY DEPTH

+



	scale	width at nut
full size	650 mm (25.59")	48 mm (1.89")

STR = stained red
BK = black

- Solid Alaskan Sitka spruce top, gloss finish stained red || gloss finish black
- Sapele back & side, gloss finish stained red || gloss finish black
- Mahogany neck, gloss finish stained || gloss finish black

- 14th fret heel to body connection
- Indian Laurel radius fretboard & bridge
- Ortega MagusPro electronics w/ tuner
- Ortega 12hole bridge

- Ortega signature walnut/maple/white pearl rosette
- 2way truss rod
- Savarez 500CJ strings
- Deluxe gig bag included



PERFORMER SERIES

SOLID SPRUCE TOP/
SOLID CEDAR TOP

SPANISH HEEL



ELECTRONICS W/ TUNER

ORTEGA
MagusPRO/G



RCE158SN
SLIM NECK



RCE158SN-TSB
SLIM NECK



RCE158SN-HSB
SLIM NECK



+



full size

scale
650 mm (25.59")

width at nut
48 mm (1.89")

TSB = tobacco
sunburst, top only
HSB = honey burst,
top only

- Solid Alaskan Sitka spruce top, gloss finish || tobacco sunburst (TSB) gloss finish || honey burst (HSB) gloss finish
- Walnut back & side, gloss finish
- Mahogany neck, gloss finish

- Indian Laurel fretboard & bridge
- Ortega MagusPro electronics w/ tuner
- Ortega 12hole bridge
- Ortega signature walnut/maple/white pearl rosette

- 2way truss rod
- Savarez 500CJ strings
- Deluxe gig bag included



RCE159MN
MEDIUM NECK



RCE159MN-L
LEFTHAND
MEDIUM NECK



RCE159SN
SLIM NECK



+



full size

scale
650 mm (25.59")

width at nut
SN = 48 mm (1.89") /
MN = 50 mm (1.97")

- Solid North American cedar top, gloss finish
- Walnut back & side, gloss finish
- Mahogany neck, gloss finish

- Indian Laurel fretboard & bridge
- Ortega MagusPro electronics w/ tuner
- Ortega 12hole bridge
- Ortega signature walnut/maple/white pearl rosette

- 2way truss rod
- Savarez 500CJ strings
- Deluxe gig bag included

PERFORMER SERIES SOLID CEDAR TOP



RCE159-8 

scale: 690 mm
width at nut: 70 mm **8string Nylon**

 **ELECTRONICS**
ORTEGA
MagusGO-8



- 8string NYLON STRING GUITAR
- Solid North American cedar top, gloss finish
- Walnut back & side, gloss finish
- Mahogany neck, gloss finish
- Tecwood fretboard (flat, 70mm at nut/78mm on 14th fret/90mm on saddle)
- Tecwood bridge
- MagusGO-8 electronics
- Ortega 8hole bridge
- Ortega signature walnut/maple/white pearl rosette
- 2way truss rod
- Ortega OCTA-8NS custom made strings
- Deluxe gig bag included



JADE 

ALL SOLID FLORENTINE CUTAWAY ORTEGA SIGNATURE ROSETTE

scale: 650 mm
width at nut: 47 mm **EXTRA SLIM NECK**

 **ELECTRONICS W/ TUNER**
ORTEGA
FISHMAN



- Solid Canadian Engelmann spruce top, gloss finish
- Solid walnut back & side, gloss finish
- Thinline body depth (90 mm)
- Maple binding/green pearl ABS purfling
- Mahogany neck, satin finish
- 14th fret heel to body connection
- Radiused (radius 400 mm - 15.75") Balsamo fretboard & bridge
- Ortega/Fishman Clasica Blend electronics w/ tuner
- 2way truss rod
- Savarez 510CJ strings
- Deluxe gig bag & static pickguard included

TRAVELER SERIES

 **ELECTRONICS**
B.BAND



NL-WALKER-MM 

NL-WALKER-WH 

	scale	width at nut
full size	625 mm (24.61")	43 mm (1.69")

MM = mahogany
WH = white



- Mahogany top, gloss finish || Agathis top, gloss finish, white
- Mahogany back & side, gloss finish || Agathis back & side, gloss finish, white
- Black ABS binding
- Mahogany neck, gloss finish || Mahogany neck, gloss finish, white
- Acacia fretboard & bridge (MM) || Sonokelin fretboard & bridge (WH)
- B.Band A1.2 electronics
- Ortega die cast tuning machines, black
- 19 frets
- Savarez 510CJ strings
- Deluxe gig bag included



TRADITIONAL SERIES

OPTIONS

MADE IN SPAIN

scales and sizes

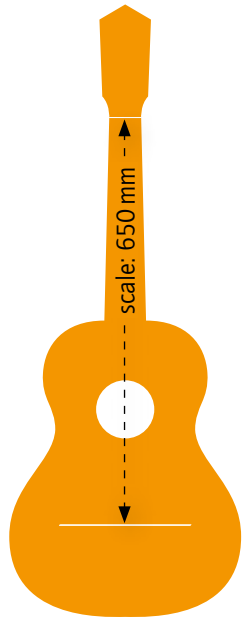

width at nut

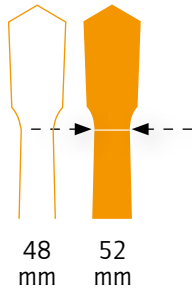

wood variations: back & sides

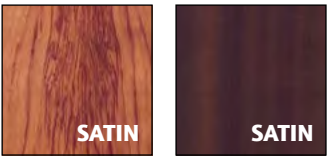

bubinga caoba



palo-rojo mahogany

wood variations: top

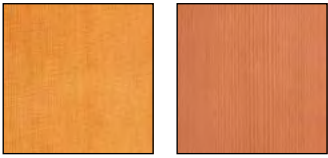

solid Canadian spruce solid Red Western cedar



mongoy maple

features



Spanish heel



12hole bridge



bag

lefthand: Rxxx L



strings

SAVAREZ
Savarez 500CRJ



TRADITIONAL SERIES

MADE IN
SPAIN

ortegaguitars.com

45



SPANISH HEEL

scale: 650 mm
width at nut: 52 mm

R180



- Solid North American cedar top, satin finish
- Bubinga back & side, satin finish
- Maple binding
- Mahogany neck, satin finish
- Rosewood fretboard & bridge
- Ortega 12hole bridge
- Savarez 500CRJ strings
- Handmade in Spain
- Deluxe gig bag included



**SPANISH HEEL
LEFTHAND**

scale: 650 mm
width at nut: 52 mm

R180L



- Solid North American cedar top, satin finish
- Bubinga back & side, satin finish
- Maple binding
- Mahogany neck, satin finish
- Rosewood fretboard & bridge
- Ortega 12hole bridge
- Savarez 500CRJ strings
- Handmade in Spain
- Deluxe gig bag included
- LEFTHAND



SPANISH HEEL

scale: 650 mm
width at nut: 52 mm

R190



- Solid North American cedar top, satin finish
- Caoba back & side, satin finish
- Maple binding
- Mahogany neck, satin finish
- Rosewood fretboard & bridge
- Ortega 12hole bridge
- Savarez 500CRJ strings
- Handmade in Spain
- Deluxe gig bag included

ACCESSORIES



HUMIGT-BK

HUMIFIERS
(see page 97)



TRADITIONAL SERIES

MADE IN SPAIN

R200



SPANISH HEEL

scale: 650 mm
width at nut: 52 mm



- Solid North American cedar top, gloss finish
- Palo-rojo back & side, gloss finish
- Maple binding
- Mahogany neck, gloss finish
- Rosewood fretboard & bridge
- Ortega 12hole bridge
- Savarez 500CRJ strings
- Handmade in Spain
- Deluxe gig bag included

R200SN



SPANISH HEEL

scale: 650 mm
width at nut: 48 mm **SN**
(slim neck)



- Solid North American cedar top, gloss finish
- Palo-rojo back & side, gloss finish
- Maple binding
- Mahogany neck, gloss finish
- Rosewood fretboard & bridge
- Ortega 12hole bridge
- Savarez 500CRJ strings
- Handmade in Spain
- Deluxe gig bag included

R200L



**SPANISH HEEL
LEFTHAND**

scale: 650 mm
width at nut: 52 mm



- Solid North American cedar top, gloss finish
- Palo-rojo back & side, gloss finish
- Maple binding
- Mahogany neck, gloss finish
- Rosewood fretboard & bridge
- Ortega 12hole bridge
- Savarez 500CRJ strings
- Handmade in Spain
- Deluxe gig bag included
- LEFTHAND

R220



SPANISH HEEL

scale: 650 mm
width at nut: 52 mm



- Solid North American cedar top, gloss finish
- Mongoy back & side, gloss finish
- Maple binding
- Mahogany neck, gloss finish
- Rosewood fretboard & bridge
- Ortega 12hole bridge
- Savarez 500CRJ strings
- Handmade in Spain
- Deluxe gig bag included

TRADITIONAL SERIES

MADE IN
SPAIN

ortegaguitars.com

47



SPANISH HEEL

scale: 650 mm
width at nut: 52 mm

R210



- Solid North American spruce top, gloss finish
- Mahogany back & side, gloss finish
- Maple binding
- Mahogany neck, gloss finish
- Rosewood fretboard & bridge
- Ortega 12hole bridge
- Savarez 500CRJ strings
- Handmade in Spain
- Deluxe gig bag included



**FLAMENCO
SPANISH HEEL**

scale: 650 mm
width at nut: 52 mm

R270F



- Solid North American spruce top, gloss finish
- Maple back & side, gloss finish
- Rosewood binding
- Mahogany neck, gloss finish
- Rosewood fretboard & bridge (flat, Flamenco)
- Flamenco scratch plates
- Ortega 12hole bridge
- Savarez 500CRJ strings
- Handmade in Spain
- Deluxe gig bag included





CUSTOM MASTER SELECTION OPTIONS

MADE IN
SPAIN

features



Spanish heel



2way truss rod



hard case

strings



Savarez 500CJ strings

scales and sizes

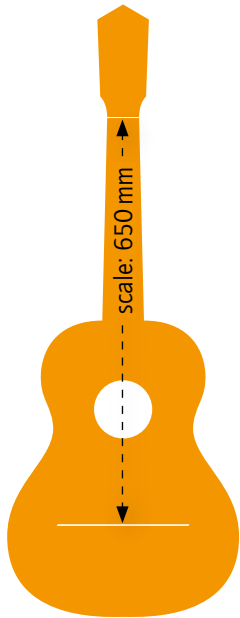

width at nut

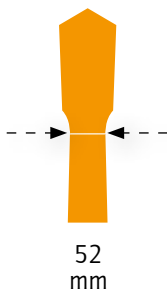

wood variations: back & sides



Mahogany



Indian
rosewood



European
walnut

wood variations: top (all gloss finish)



European
spruce



Canadian Red
Western cedar





**ALL SOLID
SPANISH HEEL**

scale: 650 mm
width at nut: 52 mm

M5CS



- Solid European spruce top, gloss finish
- Solid mahogany back & side, gloss finish
- Rosewood binding
- Mahogany neck, gloss finish
- Rosewood fretboard & bridge
- Savarez 500CJ strings
- Handmade in Spain
- Hardcase included



**ALL SOLID
SPANISH HEEL**

scale: 650 mm
width at nut: 52 mm

M3CS



- Solid Canadian Red Western cedar top, gloss finish
- Solid Indian rosewood back & side, gloss finish
- Rosewood binding
- Mahogany neck, gloss finish
- Rosewood fretboard & bridge
- Savarez 500CJ strings
- Handmade in Spain
- Hardcase included



**ALL SOLID
SPANISH HEEL**

scale: 650 mm
width at nut: 52 mm

M4CS



- Solid Canadian Red Western cedar top, gloss finish
- Solid European walnut back & side, gloss finish
- Rosewood binding
- Mahogany neck, gloss finish
- Rosewood fretboard & bridge
- Savarez 500CJ strings
- Handmade in Spain
- Hardcase included

ACCESSORIES



OWFS-1NT

FOOT STOOL
(see page 104)



OBCF

PROTECTION FOILS
(see page 96)



SIGNATURE SERIES



photo: Hendrik Holnäck

Thomas Zwijsen
Signature model/custom made



photo: Thomas Supper | ortegaguitars



**HANDMADE IN SPAIN
ALL SOLID
SPANISH HEEL**

**MADE IN
SPAIN**

scale: 650 mm
width at nut: 48 mm

TZSM/2



- Solid Canadian Spruce top, gloss finish
- Solid Spalted Maple back and Side, satin finish
- Mahogany neck, satin finish
- Maple binding w/ walnut support
- Maple fretboard radiused, 12" radiused
- Ortega 6hole bridge, pao ferro
- Ortega/Fishman Clasica Blend System w/ jack & XLR (D.I.) output w/ tuner
- 2way truss rod
- Savarez 510CJ strings
- Thomas Zwijsen Signature soft case included



ELECTRONICS W/ TUNER
**ORTEGA
FISHMAN**

Ben Woods
Signature models/custom made



**SUPER THINLINE
FLAMENCO STYLE
SPANISH HEEL
BUILT-IN ARMREST**

FLAMETAL-ONE 

scale: 650 mm
width at nut: 48 mm
Reversed Headstock
SNAKE & EAGLE top laser engraved



- Solid Western Red Cedar top, gloss finish, no sound hole
- Walnut back & side, gloss finish
- SUPER Thinline body depth (72 mm high/75 low)
- Florentine Cutaway design
- Stained mahogany neck, gloss finish
- Walnut body binding/white top purfling
- Reversed headstock, 6 in line
- Pao Ferro fretboard (flat) & bridge
- Ortega 12hole bridge
- Ortega/Fishman Clasica Blend System w/ jack & XLR (D.I.) output w/ tuner
- 2way truss rod
- Mini Die Cast tuners, gold w/ black buttons
- Savarez 510CJ strings
- FREE Flamenco double scratch plates included
- Ben Woods Signature gig bag included



**SUPER THINLINE
FLAMENCO STYLE
SPANISH HEEL
BUILT-IN ARMREST**

FLAMETAL-TWO 

scale: 650 mm
width at nut: 48 mm
Reversed Headstock



- Solid Western Red Cedar top, gloss finish
- Walnut back & side, gloss finish
- SUPER Thinline body depth (72 mm high/75 low)
- Florentine Cutaway design
- Ortega Signature rosette
- Stained mahogany neck, gloss finish
- Walnut body binding/white top purfling
- Reversed headstock, 6 in line
- Pao Ferro fretboard (flat) & bridge
- Ortega 12hole bridge
- Ortega/Fishman Clasica Blend System w/ jack & XLR (D.I.) output w/ tuner
- 2way truss rod
- Mini Die Cast tuners, gold w/ black buttons
- Savarez 510CJ strings
- FREE Flamenco double scratch plates included
- Ben Woods Signature gig bag included



**HANDMADE IN SPAIN
ALL SOLID
THINLINE FLAMENCO STYLE
SPANISH HEEL**

BWSM/2 

MADE IN SPAIN

scale: 650 mm
width at nut: 52 mm



- Solid Western Red Cedar top, gloss finish
- Solid European Walnut back & side, gloss finish
- Thinline body depth (80 mm)
- Mahogany neck, gloss finish
- Sycamore body binding
- Ebony fretboard (flat) & bridge
- Flamenco double scratch plate
- Ortega 12hole bridge
- Ortega/Fishman Clasica Blend System w/ jack & XLR (D.I.) output w/ tuner
- 2way truss rod
- Savarez 510CJ strings
- Ben Woods Signature gig bag included





photo: JR

Javier Reyes – Animals as Leaders
Signature models/custom made



**ALL SOLID
8STRING NYLON
SPANISH HEEL**

**MADE IN
SPAIN**

scale: 690 mm
width at nut: 70 mm

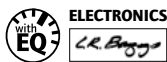

JRSM-COS



- Solid North American spruce top, gloss finish
- Solid American cocobolo back & side, gloss finish
- Mahogany neck, gloss finish
- Rosewood fretboard (flat, 70 mm at nut/ 78 mm on 14th fret/90 mm on saddle)
- Rosewood bridge
- L.R.BAGGS Element electronics
- Ortega signature rosewood/maple/ white pearl rosette
- 2way truss rod
- Ortega OCTA-8NS custom made strings – made in Germany
- Made in Spain
- Road case included



**ALL SOLID
8STRING NYLON
SPANISH HEEL**

**MADE IN
SPAIN**

scale: 690 mm
width at nut: 70 mm



JRSM-RWC



- Solid North American cedar top, gloss finish
- Solid Madagascar rosewood (certified) back & side, gloss finish
- Mahogany neck, gloss finish
- Rosewood fretboard (flat, 70 mm at nut/ 78 mm on 14th fret/90 mm on saddle)
- Rosewood bridge
- L.R.BAGGS Element electronics
- Ortega signature rosewood/maple/ white pearl rosette
- 2way truss rod
- Ortega OCTA-8NS custom made strings – made in Germany
- Made in Spain
- Road case included





Ken Taylor
Signature models/custom made

KT-WALKER-V2



4STRING

scale: 625 mm (24.60")
width at nut: 44 mm (1.73")
body depth: 88 mm (3.46")

ELECTRONICS W/ TUNER
FISHMAN



- Solid Spruce top, satin distressed tobacco burst - open pore finish
- Flamed Mahogany back & side, satin distressed tobacco burst - open pore finish
- Thinline body depth (88 mm)
- Mahogany neck, satin distressed tobacco burst
- Pao Ferro fretboard & bridge
- 19 frets
- Custom designed fretboard MOP inlays "Roman Numerals"
- Custom designed & aged Ortega D-Walker tuning machines
- Fishman PRESYS+ electronics w/ Jack & XLR output w/ tuner
- 2way truss rod
- Ortega ODW-4 balanced tension bass strings
- Deluxe gig bag included

KTSM-5

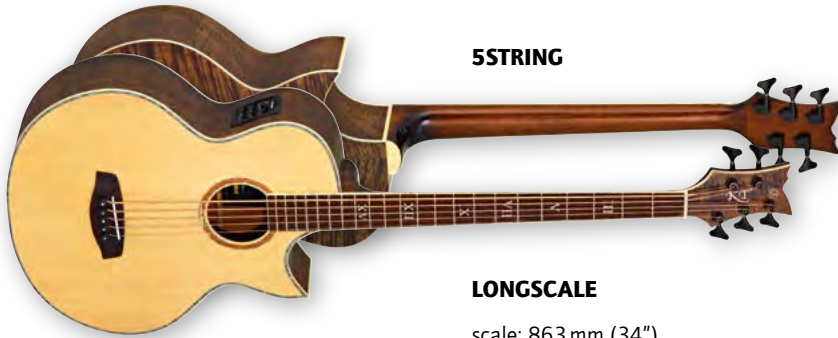

5STRING

LONGSCALE

scale: 863 mm (34")
width at nut: 45 mm (1.77")
body depth: 126 mm (4.96")

ELECTRONICS W/ TUNER
FISHMAN



- Solid North American spruce top, gloss finish
- Flamed mahogany back & side, gloss finish
- Mahogany neck, gloss finish
- Acacia fretboard & bridge
- Custom designed "Roman Numerals" fretboard inlays
- Walnut binding/white purfling
- Black hardware
- Fishman Presys+ electronics w/ tuner
- 2way truss rod
- D'Addario EXPBB170-5 strings
- Deluxe gig bag & straplocks included

KTSM-5FL



LINED FRETLESS
5STRING

LONGSCALE

scale: 863 mm (34")
width at nut: 45 mm (1.77")
body depth: 126 mm (4.96")

ELECTRONICS W/ TUNER
FISHMAN



- Solid North American spruce top, gloss finish
- Flamed mahogany back & side, gloss finish
- Mahogany neck, gloss finish
- Acacia fretboard & bridge
- Custom designed "Roman Numerals" fretboard inlays
- Walnut binding/white purfling
- Black hardware
- Fishman Presys+ electronics w/ tuner
- 2way truss rod
- D'Addario EXPBB170-5 strings
- Deluxe gig bag & straplocks included



THE PRIVATE ROOM

CUSTOM CRAFTED INSTRUMENTS

"The Private Room starts with handpicked tonewoods that are set aside to be custom crafted into exclusive guitars. This selection is limited and truly unique."

DISTRESSED SUITES

DSSUITE-E



THINLINE BODY

DISTRESSED SATIN FINISH

scale: 650 mm
width at nut: 48 mm

SN & DTS
(slim neck & distressed tobacco sunburst finish)



- Solid Alaskan spruce top, DTS, satin finish
- Mahogany back & side, DTS, satin finish
- NO body binding, walnut fretboard binding
- Mahogany neck, distressed tobacco sunburst, satin
- Heel to body connection on 14th fret
- Indian Laurel fretboard (radius, 400R) with „XII“ inlay on 12th fret
- 2way truss rod
- Spanish heel
- Ortega signature walnut/maple/white pearl rosette
- Ortega 12hole bridge, walnut
- Aged vintage tuning machines, classic 3 bar
- Ortega MagusPro electronics w/ tuner
- Savarez 500CJ strings
- Deluxe gig bag & suede leather strap included



ELECTRONICS W/ TUNER
ORTEGA
MagusPRO/G

DSSUITE-C/E



THINLINE BODY

DISTRESSED SATIN FINISH

scale: 650 mm
width at nut: 48 mm

SN & DTS
(slim neck & distressed tobacco sunburst finish)



- Solid Alaskan spruce top, DTS, satin finish
- Mahogany back & side, DTS, satin finish
- NO body binding, walnut fretboard binding
- Mahogany neck, distressed tobacco sunburst, satin
- Heel to body connection on 14th fret
- Indian Laurel fretboard (radius, 400R) with „XII“ inlay on 12th fret
- 2way truss rod
- Spanish heel
- Ortega signature walnut/maple/white pearl rosette
- Ortega 12hole bridge, walnut
- Aged vintage tuning machines, classic 3 bar
- Ortega MagusPro electronics w/ tuner
- Savarez 500CJ strings
- Deluxe gig bag & suede leather strap included



ELECTRONICS W/ TUNER
ORTEGA
MagusPRO/G





ECLIPSE SUITE



HONEY SUITE

ECLIPSESU.C/E



BUILT-IN ARMREST

ALL MAHOGANY

scale: 650 mm
width at nut: 48 mm

SN
(slim neck)



ELECTRONICS W/ TUNER
ORTEGA
MagusPRO/G



- Solid mahogany top, eclipse burst gloss finish
- Mahogany back & side, gloss finish
- Walnut top & back binding/ MOP purfling
- Walnut armrest
- Mahogany neck, gloss finish
- Indian Laurel fretboard (flat) & bridge
- 2way truss rod
- Spanish heel
- Eclipse soundhole design
- Eclipse fretboard inlay
- Ortega 12hole bridge
- A class tuning machines matte brass/black w/ black buttons
- Ortega MagusPro electronics w/ tuner
- Savarez 500CJ strings
- Deluxe gig bag & suede leather strap included

HONEYSUITE



HSB
(honey burst)

AAA FLAMED MAPLE BACK & SIDE

scale: 650 mm
width at nut: 50 mm

MN
(medium neck)



- Solid Alaskan spruce top, honey burst gloss finish
- AAA flamed maple back & side, honey burst gloss finish
- Flamed maple binding/white purfling
- Maple neck, honey burst gloss finish
- Indian Laurel fretboard (flat) & bridge
- 2way truss rod
- Spanish heel
- Ortega signature walnut/maple/white pearl rosette
- Ortega 12hole bridge
- A class tuning machines matte brass/black
- Savarez 500CJ strings
- Deluxe gig bag & suede leather strap included



STRIPED SUITES

STRIPEDSU.C/E 



BUILT-IN ARMREST

**AAA STRIPED
EBONY
BACK & SIDE**

scale: 650 mm **SN**
width at nut: 48 mm (slim neck)

 **ELECTRONICS W/ TUNER**
ORTEGA
MagusPRO/G



- Solid Alaskan spruce top, gloss finish
- AAA striped ebony back & side, gloss finish
- Acacia binding/white purfling
- Mahogany neck, gloss finish
- Indian Laurel fretboard (flat) & bridge
- 2way truss rod
- Spanish heel
- Ortega signature walnut/maple/white pearl rosette
- Ortega 12hole bridge
- A class tuning machines matte brass/black w/ black buttons
- Ortega MagusPro electronics w/ tuner
- Savarez 500CJ strings
- Deluxe gig bag & suede leather strap included

STRIPEDSU.ACB 

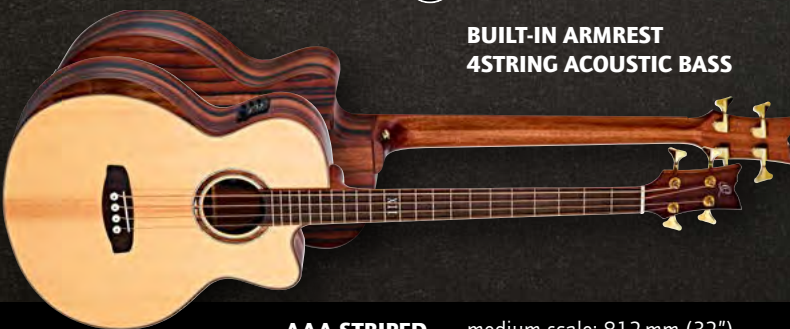

**BUILT-IN ARMREST
4STRING ACOUSTIC BASS**

**AAA STRIPED
EBONY
BACK & SIDE**

medium scale: 812 mm (32")
width at nut: 45 mm (1.77")
body depth: 122 mm (4.8")

 **ELECTRONICS W/ TUNER**
ORTEGA
MagusPRO/B



- 4 string acoustic bass
- Solid Alaskan spruce top, gloss finish
- AAA striped ebony back & side, gloss finish
- Acacia top & bottom binding/white purfling
- Mahogany neck, gloss finish
- Medium scale
- Tecwood fretboard w/ walnut binding
- Tecwood bridge
- 2way truss rod
- Ortega signature walnut/maple/white pearl rosette
- Ortega Die cast tuning machines, gold
- Ortega MagusPro electronics w/ tuner
- D'Addario EXPBB170 acoustic bass strings
- Deluxe gig bag & genuine leather strap included



ALL ACOUSTIC BASS SERIES

OPTIONS

scales and sizes

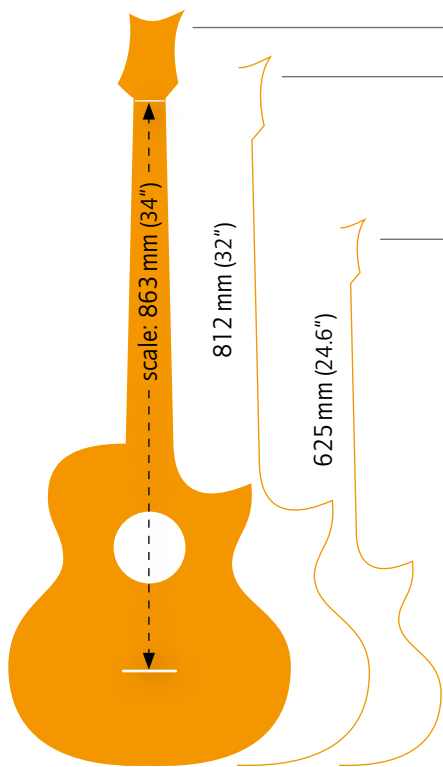

LONG SCALE

MEDIUM SCALE

TRAVELER

width at nut

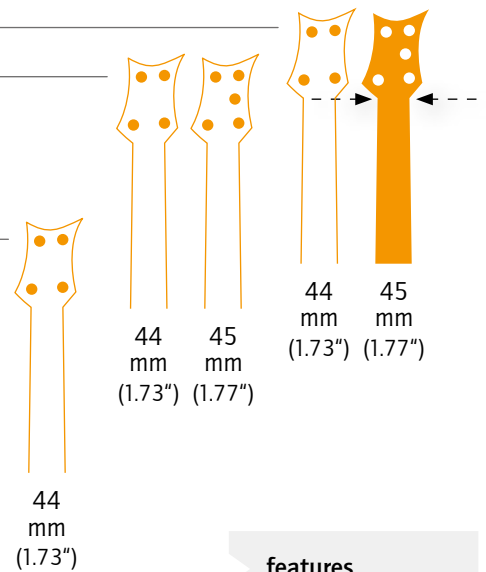

wood variations: top

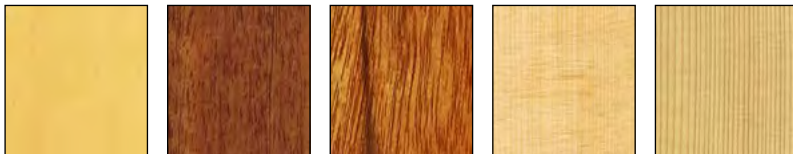

agathis

mahogany

paldao (dao)

solid Alaskan spruce

solid North American cedar

wood variations: back & sides



sapele

mahogany

paldao (dao)

walnut

agathis

color/finish variations



natural NT:
satin finish/
gloss finish

black BK:
gloss finish

open pore

features



2way truss rod



bag

strings

D'Addario

D'Addario EXPPBB170,
D'Addario EXPPBB170-5

ORTEGA®

Ortega ODW-4

body



cutaway

electronics

ORTEGA®
MagusPRO/B

Electronics w/ tuner
(see page 93)

BEAN A1.2

FISHMAN

Isys+/Presys+

DEEP TRAVELER SERIES



scale: 625 mm (24.60")
width at nut: 44 mm (1.73")
body depth: 90 mm (3.54")

MM
(mahogany)



D-WALKER-MM



- Mahogany top, gloss finish
- Mahogany back & side, gloss finish
- Mahogany neck, gloss finish
- Acacia fretboard & bridge
- Black ABS binding
- B.Band A1.2 electronics
- 19 frets
- 2way truss rod
- Ortega ODW-4 strings
- Deluxe gig bag included



scale: 625 mm (24.60")
width at nut: 44 mm (1.73")
body depth: 90 mm (3.54")

BK
(black)



D-WALKER-BK



- Agathis top, gloss finish black
- Agathis back & side, gloss finish black
- Mahogany neck, gloss finish black
- Acacia fretboard & bridge
- Ivory ABS binding
- B.Band A1.2 electronics
- 19 frets
- 2way truss rod
- Ortega ODW-4 strings
- Deluxe gig bag included





DEEP SERIES

D538-4



SOLID SPRUCE

medium scale: 812 mm (32")
width at nut: 45 mm (1.77")
body depth: 122 mm (4.80")

4 STRING



ELECTRONICS W/ TUNER
ORTEGA
MagusPRO/B

- Solid Alaskan spruce top, satin finish
- Sapele back & side, open pore finish
- Mahogany neck, open pore finish
- Pao Ferro fretboard w/ black ABS binding
- Pao Ferro bridge
- Black ABS binding/bk-wh-bk purfling
- Chrome hardware
- ORTEGA MagusPRO/B electronics w/ tuner
- 2way truss rod
- D'Addario EXPPBB170 acoustic bass strings

D558-4



SOLID SPRUCE

medium scale: 812 mm (32")
width at nut: 45 mm (1.77")
body depth: 122 mm (4.80")

4 STRING



ELECTRONICS W/ TUNER
ORTEGA
MagusPRO/B

- Solid Alaskan spruce top, satin finish
- Walnut back & side, open pore finish
- Mahogany neck, open pore finish
- Pao Ferro fretboard w/ black ABS binding
- Pao Ferro bridge
- Ivory ABS binding/bk-wh-bk purfling
- Gold hardware
- ORTEGA MagusPRO/B electronics w/ tuner
- 2way truss rod
- D'Addario EXPPBB170 acoustic bass strings

D3C-5



5STRING

LONGSCALE

scale: 863 mm (34")
width at nut: 45 mm (1.77")
body depth: 126 mm (4.96")



ELECTRONICS W/ TUNER
FISHMAN

- Paldao (dao) top, gloss finish
- Paldao (dao) back & side, gloss finish
- Mahogany neck, gloss finish
- Acacia fretboard & bridge
- Walnut binding/white purfling
- Black hardware
- Fishman Isis+ electronics w/ tuner
- 2way truss rod
- D'Addario EXPPBB170-5 strings
- Deluxe gig bag & straplocks included



ACCESSORIES



OABCSTD

ACOUSTIC BASS CASE
(see page 102)



OSL2-85BR

GENUINE LEATHER STRAP
(see page 78)



4STRING

medium scale: 812 mm (32")
width at nut: 44 mm (1.73")
body depth: 126 mm (4.96")



D2-4

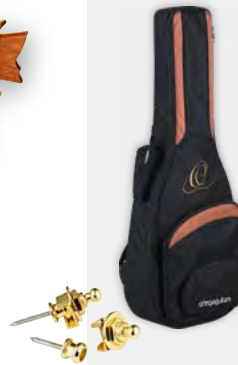

- Solid North American cedar top, satin finish
- Walnut back & side, satin finish
- Mahogany neck, satin finish
- Acacia fretboard & bridge
- Maple binding / ABS pearl purfling
- Gold hardware
- Fishman Presys+ electronics w/ tuner
- 2way truss rod
- D'Addario EXPBB170 strings
- Deluxe gig bag & straplocks included



**FRETLESS
4STRING**

medium scale: 812 mm (32")
width at nut: 44 mm (1.73")
body depth: 126 mm (4.96")



D2-4FL

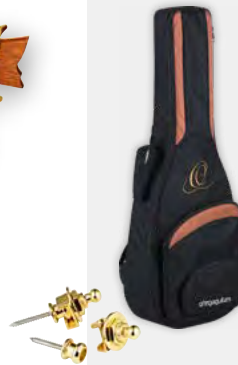

- Solid North American cedar top, satin finish
- Walnut back & side, satin finish
- Mahogany neck, satin finish
- Acacia fretboard & bridge
- Maple binding / ABS pearl purfling
- Gold hardware
- Fishman Presys+ electronics w/ tuner
- 2way truss rod
- D'Addario EXPBB170 strings
- Deluxe gig bag & straplocks included





MANDOLINS & BANJOS



photo: Maria Athens

MANDOLINS



scale: 345 mm (13.58")
width at nut: 28 mm (1.10")

NA
(natural)

RMA5NA

- Mahogany top, open pore satin finish
- Mahogany back (arched) & side, open pore satin finish
- Mahogany neck, satin finish
- Ovangkol fretboard & bridge
- 2way truss rod
- 20 frets
- D'Addario EXP74 strings



scale: 345 mm (13.58")
width at nut: 28 mm (1.10")

VS
(vintage sunburst)

RMA5VS

- Mahogany top, open pore vintage sunburst satin finish
- Mahogany back (arched) & side, open pore vintage sunburst satin finish
- Mahogany neck, satin finish
- Ovangkol fretboard & bridge
- 2way truss rod
- 20 frets
- D'Addario EXP74 strings



RMAE40SBK 

scale: 345 mm (13.58")
width at nut: 28 mm (1.10") **SBK**
(satin black)

 **PICKUP BUILT-IN SYSTEM**
PICKUP BUILT-IN



- Spruce top, satin black finish
- Maple back (arched) & side, satin black finish
- Maple neck, satin black finish
- Rosewood fretboard & bridge
- 2way truss rod
- 20 frets
- Piezo bridge with tone & volume control, passive
- D'Addario EXP74 strings
- Deluxe gig bag included



RMFE40SBK 

scale: 345 mm (13.58")
width at nut: 28 mm (1.10") **SBK**
(satin black)

 **PICKUP BUILT-IN SYSTEM**
PICKUP BUILT-IN



- Spruce top, satin black finish
- Maple back (arched) & side, satin black finish
- Maple neck, satin black finish
- Rosewood fretboard & bridge
- 2way truss rod
- 24 frets
- Piezo bridge with tone & volume control, passive
- D'Addario EXP74 strings
- Deluxe gig bag included



RMFE90TS 

scale: 345 mm (13.58")
width at nut: 28 mm (1.10") **TS**
(tobacco sunburst)

 **ELECTRONICS W/ TUNER**
ORTEGA



- Solid spruce top, gloss tobacco sunburst finish
- Maple back (arched) & side, gloss tobacco sunburst finish
- Maple neck, gloss tobacco sunburst finish
- Rosewood fretboard & ebony bridge
- Ortega SIT electronics w/ tuner
- 2way truss rod
- 24 frets
- One piece die cast tailpiece, gold
- D'Addario EXP74 strings
- Deluxe gig bag included



RMFE100AVO 

scale: 345 mm (13.58")
width at nut: 28 mm (1.10") **AVO**
(antique violin oil)

 **ELECTRONICS W/ TUNER**
ORTEGA



- Solid distressed spruce top, antique violin oil finish
- Solid flamed maple back (arched) & side, distressed antique violin oil finish
- Maple neck, gloss tobacco sunburst finish
- Ebony fretboard & ebony bridge
- Ortega SIT electronics w/ tuner
- 2way truss rod
- 24 frets
- One piece die cast tailpiece, gold
- Grover tuning machines
- D'Addario EXP74 strings
- Deluxe gig bag included



BANJOS – RAVEN SERIES



5STRING BANJO



5STRING BANJO, OPEN BACK



6STRING GUITAR BANJO

BUILT-IN PICKUP SYSTEM
with EQ PICKUP BUILT-IN

OBJ250-SBK

- Mahogany neck & resonator
- Ovangkol fretboard
- Mahogany ply rim
- 24 brackets, chrome hardware
- Remo ebony head, black
- Die cast machine head
- D'Addario J60 5string Banjo, Nickel Light, 9-20
- Deluxe Banjo bag included



OBJE2500P-SBK

- Mahogany neck
- Ovangkol fretboard
- Mahogany ply rim
- 24 brackets, chrome hardware
- Remo ebony head, black
- Die cast machine head
- Built-in pickup system w/ volume control
- D'Addario J60 5string Banjo, Nickel Light, 9-20
- Deluxe Banjo bag included



OBJ350/6-SBK

- Mahogany neck & resonator
- Ovangkol fretboard
- Aluminum rim
- Chrome armrest, Ortega engraved
- 30 brackets, chrome hardware
- Remo ebony head, black
- Die cast machine head
- D'Addario .012 -.053 strings
- Deluxe Banjo bag included



BUILT-IN PICKUP SYSTEM
with EQ PICKUP BUILT-IN



6STRING GUITAR BANJO



5STRING BANJO



5STRING BANJO

OBJE350/6-SBK

- Mahogany neck & resonator
- Ovangkol fretboard
- Aluminum rim
- Chrome armrest, Ortega engraved
- 30 brackets, chrome hardware
- Remo ebony head, black
- Die cast machine head
- Built-in pickup system w/ volume control
- D'Addario .012 -.053 strings
- Deluxe Banjo bag included



OBJ450-SBK

- Mahogany neck & resonator
- Rosewood fretboard
- Mahogany ply rim
- 24 brackets, chrome hardware
- Remo ebony head, black
- Rolled brass tone ring
- Geared machine head
- D'Addario J60 5string Banjo, Nickel Light, 9-20
- Deluxe Banjo bag included



OBJ650-SBK

- Mahogany neck & resonator
- Rosewood fretboard
- 3ply solid maple rim
- Chrome armrest, Ortega engraved
- 24 brackets, chrome hardware
- One piece flange
- Remo ebony head, black
- Zinc alloy tone ring
- Die cast machine head
- D'Addario J60 5string Banjo, Nickel Light, 9-20
- Deluxe Banjo bag included



OBJ550W-SNT



SATIN FINISH



- 5string Banjo
- Walnut neck
- Burl walnut resonator
- Rosewood fretboard
- Walnut ply rim
- Chrome armrest, Ortega engraved
- 24 brackets
- Flat flange
- Chrome hardware
- Remo head, renaissance
- Rolled brass tone ring
- Geared machine head
- D'Addario J60 5string Banjo, Nickel Light, 9-20
- Deluxe Banjo bag included

OBJ750-MA



- 5string Banjo
- Hard maple neck
- Flamed maple resonator
- Rosewood fretboard
- 3ply solid maple rim
- Chrome armrest, Ortega engraved
- 24 brackets
- One piece flange
- Chrome hardware
- Remo head, coated
- Brass tone ring
- Geared machine head
- Natural gloss on maple
- D'Addario J60 5string Banjo, Nickel Light, 9-20
- Deluxe Banjo bag included

OBJ850-MA



ELABORATELY CARVED HEEL AND HEADSTOCK



- 5string Banjo
- Hard maple neck
- Flamed maple resonator
- Rosewood fretboard
- 3ply solid maple rim
- Golden armrest, Ortega engraved
- 24 brackets
- One piece flange
- Golden hardware
- Remo head, Weatherking clear
- Brass tone ring
- Geared machine head
- Gloss on flamed maple
- D'Addario J60 5string Banjo, Nickel Light, 9-20
- Deluxe Banjo bag included

OBJ950-FMA



ALL FLAMED MAPLE



- 5string Banjo
- Flamed maple neck
- Flamed maple resonator
- Ebony fretboard
- 3ply solid maple rim
- Golden armrest, Ortega engraved
- 24 brackets
- One piece flange
- Golden hardware
- Remo head, coated
- Bell brass tone ring
- Geared machine head
- Gloss on all flamed maple
- D'Addario J60 5string Banjo, Nickel Light, 9-20
- Deluxe Banjo bag included



AMPLIFICATION SERIES



ORTEGA ACOUSTIC AMPLIFICATION - THE FIRST ACOUSTIC AMP HEAD

With the introduction of the first acoustic amplification head, H ONE, Ortega sets a milestone in flexibility and sound. Featuring true 100 Watt power and two channels in combination with the latest SMT & DSP technology, the H ONE delivers what acoustic players have been searching for. With a satin-finished real ash housing, the H ONE head looks as good as it sounds.

AMPLIFIER

H ONE

- 100 Watt RMS
- 1/4" and 1/4"/XLR combination inputs
- 2x channels
- Built-in DSP reverb & chorus
- Effect send/return
- Headphone out
- PRE/POST EQ D.I. out
- Speaker A/B out
- Carry bag included



The ORTEGA acoustic amplification S ONE and STWO speaker cabinets are the perfect complement to the H ONE 100 Watt amplifier head. Each cabinet features a satin finished real ash housing, tour-grade spring loaded handles and a speaker pole mount for exceptional convenience and durability. Use separately, or in combination for the ultimate in flexible performance.

SPEAKER CABINET

S ONE

- 150 Watt / 4 Ohm
- 40 Hz - 20 kHz frequency range
- 6.5" speaker and additional 3" tweeter
- Carry bag included

STWO

- 150 Watt / 4 Ohm
- 40 Hz - 20 kHz frequency range
- 8" speaker
- Carry bag included

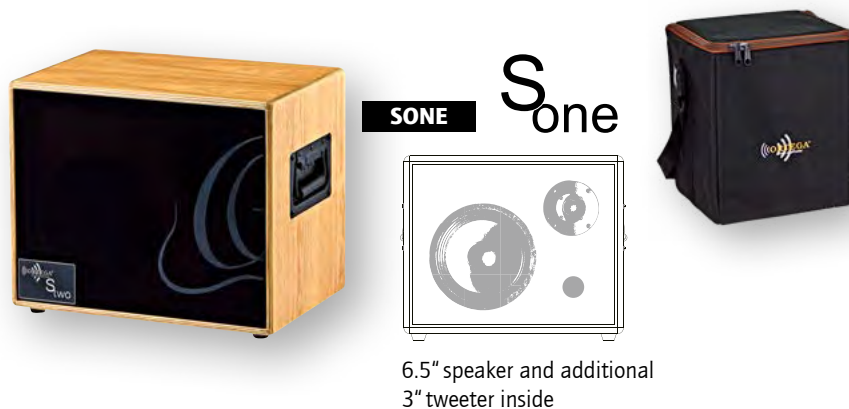

6.5" speaker and additional 3" tweeter inside



8" speaker inside



Speaker Pole Mount



Closed back



Configure as a half stack using the S ONE 6.5" speaker with 3" tweeter to emulate a typical acoustic combo amp

Add the STWO 8" sub cabinet to build a full stack with extra rich, resonant bass response



STOMP BOX EFFECT SERIES

ORTEGA QUANTUMloop - DIGITAL MULTI PERCUSSION STOMP BOX & LOOPER

Choose between **16 DIFFERENT** BUILT-IN DRUM & PERCUSSION SAMPLED SOUNDS...

... PLUS ADD 4 CUSTOM SAMPLES (2 PER BANK) VIA USB.

20 AVAILABLE SAMPLED SOUNDS!

FREE ONLINE DOWNLOAD for sound import software (Mac & Windows)

BANK A		BANK B	
DRY KICK DRUM	SLAP CAJON	BALLAD SNARE	FINGER SNIP
FAT KICK DRUM	DOUMBK SLAP	SOUL SNARE	SHORT SHAKE
SWEET KICK DRUM	COWBELL	THE RIM	TAMBOURINE
80'S ELECTRO	PERSONAL 1	FOOT HIHAT	PERSONAL 1
DEEP CAJON	PERSONAL 2	THE CLAP	PERSONAL 2



For informational video scan QR Code



CHANGE BETWEEN SOUNDS ON THE FLY. WITH 20 SAMPLES AND A LOOPER, YOUR POSSIBILITIES ARE ENDLESS.



QUANTUMexp

For maximum performance add the **QUANTUMexp** to your setup. Once connected with the QUANTUMloop via "trigger input" the sounds of BANK B are under the control of QUANTUMexp.

The QUANTUMexp operates "active" and includes a 9V battery.



QUANTUMloop

DIGITAL STOMP BOX & LOOPER with 16 built-in drum & percussion samples!

BUILT-IN LOOPER for instrument & sound banks

- 16 pre-installed sounds
- 4 empty slots for custom samples
- Built-in looper with unlimited numbers of overdubs
- Loop length: Up to 5 minutes
- Software for uploads & erase (free online download) - Mac & Windows
- Comfortable ergonomic design
- Solid mahogany wood housing
- Non-slip bottom coating & foot rest
- IN & OUT 6.3 mm (1/4") jack - True Bypass



- Removable foot rest (hook & loop)



- Trigger input, instrument in and sweeping looper volume control



- Sweeping volume control, Dynamic (velocity sensitivity) ON/OFF, instrument out (a true discrete pass-through) & USB port for sound import



FREE POWER SUPPLY included!

- FREE 9V certified quality power supply included

ORTEGA DIGITAL STOMP BOXES - PERFECT FOR SINGER/SONGWriters ON THE GO OR IN THE STUDIO

The Ortega **HORSE KICK V2** & **HORSE KICK PRO** digital stomp boxes are great tools for guitarists, singers, songwriters and street performers wanting to add a percussive element to any performance. With digital samples of real percussion sounds the HORSE KICK Stomp Boxes are way ahead of any existing analog/acoustic stomp boxes currently on the market. Just connect your favorite HORSE KICK to any amplifier or sound system and enhance your solo performance.



Choose between **5 DIFFERENT PERCUSSION SAMPLES:**

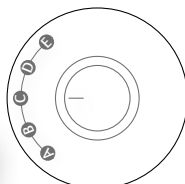

- E: Tambourine
- D: Cabasa
- C: Cowbell
- B: Kick Drum
- A: Cajon Bass

HORSEKICKPRO

DIGITAL STOMP BOX with multiple built-in digital samples of percussion sounds that can be played on its own, as a percussive instrument, or blended with your stringed instrument signal through the output.

- Digital samples of percussion instruments – just choose between 5 different percussion samples and tap your foot
- Comfortable ergonomic design for foot tapping
- Solid sapele (mahogany) wood housing
- Non-slip bottom coating
- Velocity sensitive for an expressive experience
- Sweeping volume control to adjust percussion sounds (blend the percussion sound with the unaffected instrument signal together through the output to one channel)
- 6.3 mm (1/4") input & output jack
- **Powered 9V battery or power supply included**

Your **HANDS FREE** rhythm section



HORSEKICKV2

DIGITAL STOMP BOX with built-in digitally sampled "Cajon Bass" sound

- Digital sample of a "Cajon Bass" sound – just tap your foot
- Comfortable ergonomic design for foot tapping
- Solid ash wood housing
- Non-slip bottom coating
- Velocity sensitive for an expressive experience
- Sweeping volume control to adjust percussion sound
- 6.3 mm (1/4") input & output jack
- **Powered 9V battery or power supply included**

ORTEGA ANALOG STOMP BOX - PERFECT FOR PLAYERS ON THE GO & STREET PERFORMERS

The Ortega **ANNAlog** analog percussion stomp box is the perfect tool for guitarists, singer/songwriters and street performers wanting to add a percussive element to any performance. With it's analog design, no battery or power supply is needed. Plug-In and play. Detailed inner construction minimizes surrounding noise to maximize bass punch. Equipped with an input and output, the True Bypass allows you to blend the percussive sound with your instrument signal to a single channel.



NO BATTERY or POWER SUPPLY needed!

ANNAlog

ANALOG STOMP BOX with built-in sound optimized piezo technology.

- **No battery or power supply needed**
- **Input & output – only one channel needed**
- Comfortable ergonomic design for foot tapping
- Solid cherry wood housing
- Non-slip bottom coating
- Minimized surrounding noise
- Maximized bass punch
- Sweeping volume control to adjust the level of bass punch
- 6.3 mm (1/4") input & output jack

Your **HANDS FREE** rhythm section

STB-DEMO-EQ



STOMP BOX DEMO STATION, equipped with HORSEKICKPRO, HORSEKICKV2 and ANNAlog, cables and power supply included.



PERCUSSION SERIES

STOMP BOX CAJON BUNDLE

Your **HANDS FREE** rhythm section

BUNDLE ALSO AVAILABLE IN LEFT FOOT CONFIGURATION



OSTBCJ-BU



OSTBCJ-L-BU

Our hands free percussion products are designed specifically for the stringed instrument player. Go busking in the streets, recording in a studio, jam with friends or write a song, adding percussive rhythm elements, all while playing your stringed instrument.

The ORTEGA STOMP BOX CAJON BUNDLE OSTBCJ-BU & OSTBJ-L-BU includes:



ORTEGA Cajon (with bundle only)

Size: 30 cm (11.75") W x 46 cm (18") H x 30 cm (11.75") D

Resonating body: Baltic Birch

Front plate OSTBJ-BU: Ammara wood

Front plate OSTBJ-L-BU: Baltic Birch (Golden Brown)

- 2 internal snare wires
- Adjustable front plate for more sound options
- Curved corners for more comfort
- Delivers full, rich tone
- Made in Europe



FREE Cajon backpack bag included!



ORTEGA CAJON PEDAL OCJP-GB or OCJP-L-GB

- Heavy duty metal ground plate and metal pedal
- Soft foam beater (length adjustable)
- Cradle-like mount - fits all common Cajons
- Adjustable spring tension (pedal)



FREE Cajon pedal gig bag & drum key included!



Example right foot

TAP IT THE WAY YOU FEEL MOST COMFORTABLE!



Your
**HANDS
FREE**
rhythm section

CAJON PEDAL



OCJP-GB



LEFT FOOT

OCJP-L-GB



You already own a Cajon? The Ortega Percussion Cajon Pedal attaches firmly with yours. This pedal leaves your hands unrestricted to play along with your stringed instrument while keeping a steady kick drum rhythm beneath.

Create an infinite amount of grooves with your foot while your hands focus on playing guitar!

- Heavy duty metal ground plate and metal pedal
- Soft foam beater (length adjustable)
- Cradle-like mount - fits all common Cajons
- Adjustable spring tension (pedal)

FREE Cajon Pedal gig bag & drum key included!

GUITARIST FOOT TAMBOURINE



OGFT

The Guitarist Foot Tambourine is the perfect match for any stringed instrument player. This light and versatile "hands free" rhythm tool delivers a bright cutting tone, yet not overpowering. Easily mounted on your foot, it will go with any beat.

- Made from rubber wood in Ortega orange
- Bright, light accent for any stringed instrument
- Ergonomic design and hassle-free mounting
- 4 pairs stainless steel jingles

SINGER/SONGWRITER FOOT TAMBOURINE



OSSFT

The Singer/Songwriter Foot Tambourine is the perfect rhythm accessory for acoustic performances, studio applications or a fun jam session. The 5 pairs of stainless steel jingles deliver a precise, light shimmering sound in a small pocket friendly design.

- Made from rubber wood in Ortega orange
- Bright, light accent for any stringed instrument
- Ergonomic design and hassle-free mounting
- 5 pairs stainless steel jingles



ACCESSORIES OVERVIEW

CAPOS

(see page 74)



VEGAN STRAPS & ACCESSORIES

(see page 76)



GUITAR STRAPS

(see page 77)



UKULELE STRAPS

(see page 79)



MANDOLIN & BANJO STRAPS

(see page 80)



TUNERS

(see page 81)



ACCESSORIES

OVERVIEW

DIGITAL WIRELESS SYSTEM

(see page 82)



CABLES

(see page 84)



STRINGS

(see page 86)



PICKS

(see page 88)



STRAP LOCKS

(see page 90)



TUNING MACHINES

(see page 90)



CABLES & POWER

(see page 92)



PREAMPS & PICKUPS

(see page 93)



USEFUL HELPERS

(see page 94)



CARE

(see page 96)



HUMIDIFIERS

(see page 97)



BAGS

(see page 98)



CASES

(see page 101)



STANDS

(see page 104)



HANGERS

(see page 105)





CAPOS



TWINCAPO-CR



TWINCAPO-SBK



Bag included

**2 IN 1
ONE CAPO
FOR CURVED + FLAT
FRETBOARDS**



Flat



Curved

TWINCAPOS CURVED/FLAT

Ortega Guitars' brand new TWINcapo is not a one-trick-pony! It covers flat fretboards as well as curved fretboards. Available in satin black/orange & gloss chrome/black.

- High-grade alloy
- Covers FLAT & CURVED/RADIUS fretboards
- Perfect silicone cushion
- Designed for acoustic guitars, classic guitars (up to 52 mm nut) & electric guitars

Available models:

TWINCAPO-CR

Gloss chrome/black silicone cushion

TWINCAPO-SBK

Satin black/orange silicone cushion



OCAPO-SBK



OCAPO-CR



SMCPAD-OR



Bag included



CAPOS FLAT

Easily adjustable design made of aluminum alloy and silicone cushion.

OCAPO-SBK

Satin black, FLAT fretboard up to 52 mm nut width

OCAPO-CR

Chrome, FLAT fretboard up to 52 mm nut width

Made of aluminum alloy the "SPIDER MONKEY" Capos allow micro adjustment for exact tension. Together with a perfect silicone cushion the need to retune the instrument is dramatically reduced.

SMCPAD-OR

Designed for FLAT fretboards, up to 52 mm width at nut



OCAPOCV-SBK



OCAPOCV-CR



Bag included



SMCPADCV-SBK

CAPOS CURVED

Easily adjustable design made of aluminum alloy and silicone cushion.

OCAPOCV-SBK

Satin black, CURVED (radius) fretboard up to 52 mm nut width

OCAPOCV-CR

Chrome, CURVED (radius) fretboard up to 52 mm nut width

Made of aluminum alloy the "SPIDER MONKEY" Capos allow micro adjustment for exact tension. Together with a perfect silicone cushion the need to retune the instrument is dramatically reduced.

SMCPADCV-SBK

Designed for CURVED (radius) fretboards, up to 52 mm width at nut



Bag included



UCAPOUKE-CR

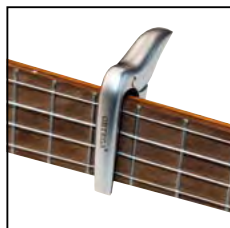

CAPO FLAT

Easily adjustable design made of aluminum alloy and silicone cushion.

UCAPOUKE-CR

Chrome, optimized for Ukulele and Banjo

THE BLACK CHROME EDITION INCLUDES A PREMIUM PRESENTATION GIFT BOX



CAPOS FLAT/CURVED/UKULELE & BANJO

SPECIAL EDITION of the ever popular ORTEGA CAPO Series features a stunning BLACK CHROME surface over aluminum and a premium presentation gift box.

Easily adjustable design made of aluminum alloy with a silicone cushion.

Available versions:

UCAPO-BCR - FLAT (classic, fretboards up to 52 mm nut width)

UCAPOCV-BCR - CURVED (radius fretboards up to 52 mm nut width)

UCAPOUKE-BCR - optimized for Ukulele & Banjo



UCAPO-BCR



UCAPOCV-BCR



UCAPOUKE-BCR





VEGAN STRAPS & ACCESSORIES

100% PHTHALATE FREE! 100% HYDROLYSIS FREE! 100% RECYCLABLE!

VEGAN PREMIUM

A new revolutionary vegan laminated synthetic material is the basis for one of the world's first ECO-friendly straps.

The unique and patented material feels so much like leather that it is nearly impossible to tell the difference.

ECONOMICAL & ENVIRONMENTALLY FRIENDLY

This technology is based on the latest generation of phthalate-free PVC (Polyvinyl Chloride).

100% RECYCLABLE

This material can be totally recycled and reused.

PVC MATERIAL FEATURES

- Vegan
- Resistant to fungi, bacteria & insects
- Weather resistant
- Durable
- Made with low power consumption
- Recyclable



GUITAR/BASS STRAPS – VEGAN SERIES

With embroidered logo. 60 mm (2.36") width, length up to 1460 mm (57.48").

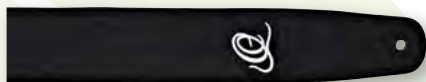

OSVG-BK
black



OSVG-TN
tan

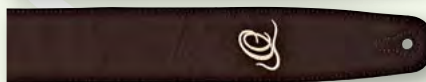

OSVG-BR
brown



OSVG-RD
red



UKULELE STRAPS – VEGAN SERIES

With embroidered logo. 40 mm (1.57") width, length up to 1360 mm (53.55"). Includes CONNECT Headstock Tie, to securely attach the strap to your headstock.



OSVU-BK black
CONNECT Headstock Tie included



OSVU-TN tan
CONNECT Headstock Tie included



OSVU-BR brown
CONNECT Headstock Tie included



OSVU-RD red
CONNECT Headstock Tie included



CONNECT – VEGAN SERIES

VEGAN headstock strap connector. Perfect to attach your strap on the headstock of guitars, ukuleles, mandolins and other stringed instruments. NO additional strap button needed on the heel of instrument.



CONNECT-BK
black



CONNECT-TN
tan



Guitar



Ukulele

COTTON STRAPS - HIGHLAND SERIES

Made from 100% cotton and equipped with strong FAUX LEATHER ends. 49 mm (1.93") width, up to 1580 mm (62.2") length, embossed logo.



OCS-100
"faded pink"

OCS-110
"stars"



OCS-120
"faded grey"

OCS-130
"faded brown"

OCS-140
"scottish dark"

OCS-150
"scottish bright"

COTTON STRAPS - CASUAL SERIES

Made from 100% cotton and equipped with strong FAUX LEATHER ends. 49 mm (1.93") width, up to 1580 mm (62.2") length, embossed logo.



OCS-200
"coal cotton"

OCS-210
"grey cotton"

OCS-220
"brown cotton"

OCS-230
"ice cotton"

OCS-240
"khaki cotton"

OCS-250
"burgundy cotton"

OCS-260
"orange cotton"

OCS-270
"blue cotton"

COTTON STRAPS - WORLD SERIES

Made from 100% cotton and equipped with strong FAUX LEATHER ends. 49 mm (1.93") width, up to 1580 mm (62.2") length, embossed logo.



OCS-400
"indian sky"

OCS-410
"indian arts"

OCS-420
"desert night"

OCS-430
"frisco dance"

OCS-440
"african dance"

OCS-450
"icelander"

OCS-460
"machu pichu"

OCS-470
"maya dance"

COTTON STRAPS - SPRING SERIES

Made from 100% cotton and equipped with strong FAUX LEATHER ends. 49 mm (1.93") width, up to 1580 mm (62.2") length, embossed logo.



OCS-300
"coal jean"

OCS-310
"brown jean"

OCS-320
"pink jean"

OCS-330
"sun jean"

OCS-340
"green jean"

OCS-350
"blue jean"

OCS-360
"purple jean"

COTTON STRAPS - CREATIVE SERIES

Made from 100% cotton and equipped with strong FAUX LEATHER ends. 49 mm (1.93") width, up to 1580 mm (62.2") length, embossed logo.



OCS-500
"striped"

OCS-510
"modern arts"

OCS-520
"70's psycho"

OCS-530
"70's plants"

OCS-540
"classic white"

OCS-550
"classic blue"

OCS-560
"classic yellow"



ALL cotton guitar straps incl. pick holder pocket



GUITAR STRAPS - NYLON & LEATHER

NYLON STRAPS UNICOLOR

50 mm (1.97") width, leather ends with embossed Logo, up to 1800 mm (70.86") length



- ONS50STD-BK**
"black"
- ONS50STD-BR**
"brown"
- ONS50STD-WH**
"white"
- ONS50STD-RD**
"red"
- ONS50STD-BL**
"blue"

NYLON STRAPS - EXTRA WIDE "SKULLS"

65 mm (2.55") width, leather ends with embossed Logo, up to 1460 mm (57.48") length



- OSN-65SKBK**
"black"
- OSN-65SKBU**
"burgundy red"
- OSN-65SKCO**
"charcoal"

SUEDE LEATHER STRAPS

Soft and smooth suede leather, 65 mm (2.56") width, up to 1420 mm (55.9") length



- OSS2-BK**
"black", O-signet embroidered
- OSS2-BR**
"brown", O-signet embroidered
- OSS2-HO**
"honey", O-signet embroidered

NYLON GUITAR STRAPS/SUPPORT - HOOK

Special nylon made acoustic guitar strap with soundhole hook. 37 mm (1.45") width at upper part.

The strap/support is appx. 800 mm (31.5") long and adjustable up to appx. 1000 mm (39").



- OGSHK-BK**
"black"
- OGSHK-BR**
"brown"



GENUINE LEATHER STRAPS

Genuine leather, extra wide 85 mm (3.35"), perfect for guitar and bass, up to 1420 mm (55.9") length



- OSL2-85BK**
"black"
- OSL2-85BR**
"brown"

NYLON STRAPS MOTIF

50 mm (1.97") width, leather ends, up to 1420 mm (55.9") length



- OSN-50OGT**
"ortegaguitars"
- OSN-50EGY**
"egypt"
- OSN-50EVO**
"evolution"
- OSN-50COR**
"corn circuit"
- OSN-50BUB**
"bubbles"



UKULELE STRAPS - COTTON

COTTON UKULELE STRAPS - HIGHLAND SERIES

Made from 100% cotton and equipped with strong FAUX LEATHER ends. 37 mm (1.45") width, up to 1390 mm (54.33") length, embossed logo.



OCS-100U
"faded pink"

OCS-110U
"stars"



OCS-120U
"faded grey"

OCS-130U
"faded brown"

OCS-140U
"scottish dark"

OCS-150U
"scottish bright"

COTTON UKULELE STRAPS - CASUAL SERIES

Made from 100 % cotton and equipped with strong FAUX LEATHER ends. 37 mm (1.45") width, up to 1390 mm (54.33") length, embossed logo.



OCS-200U
"coal cotton"

OCS-210U
"grey cotton"



OCS-220U
"brown cotton"

OCS-230U
"ice cotton"

OCS-240U
"khaki cotton"

OCS-250U
"burgundy cotton"

OCS-260U
"orange cotton"

OCS-270U
"blue cotton"

COTTON UKULELE STRAPS - SPRING SERIES

Made from 100% cotton and equipped with strong FAUX LEATHER ends. 37 mm (1.45") width, up to 1390 mm (54.33") length, embossed logo.



OCS-300U
"coal jean"

OCS-310U
"brown jean"

OCS-320U
"pink jean"



OCS-330U
"sun jean"

OCS-340U
"green jean"

OCS-350U
"blue jean"

OCS-360U
"purple jean"

COTTON UKULELE STRAPS - WORLD SERIES

Made from 100 % cotton and equipped with strong FAUX LEATHER ends. 37 mm (1.45") width, up to 1390 mm (54.33") length, embossed logo.



OCS-400U
"indian sky"

OCS-410U
"indian arts"

OCS-420U
"desert night"



OCS-430U
"frisco dance"

OCS-440U
"african dance"

OCS-450U
"icelander"

OCS-460U
"machu pichu"

OCS-470U
"maya dance"



UKULELE STRAPS - COTTON & NYLON

COTTON UKULELE STRAPS - CREATIVE SERIES

Made from 100 % cotton and equipped with strong FAUX LEATHER ends. 37 mm (1.45") width, up to 1390 mm (54.33") length, embossed logo.



OCS-500U
"striped"

OCS-510U
"modern arts"

OCS-520U
"70's psycho"



OCS-530U
"70's plants"

OCS-540U
"classic white"

OCS-550U
"classic blue"

OCS-560U
"classic yellow"

NYLON UKULELE STRAPS/SUPPORT HOOK

Special "slim" nylon uke strap with soundhole hook, 37 mm (1.45") width at upper part, up to 700 mm (27.56") length



OUSHK-BK
"black"

OUSHK-BR
"brown"

OUSHK-WH
"white"

OUSHK-RD
"red"

OUSHK-BL
"blue"



NYLON UKULELE STRAPS

Special "slim" nylon uke straps, leather ends, 37 mm (1.45") width, up to 1350 mm (53.15") length



OUS-GRFL
"green flower"

OUS-MAY
"maya"

OUS-ORFL
"orange flower"

OUS-PALM
"palm island"

OUS-SUN
"sundown"

OUS-VOO
"voodoo"

MANDOLIN & BANJO STRAPS - LEATHER

MANDOLIN STRAPS

Leather, up to 1700 mm (66.92") length



OSM-BK
standard, black

OSM-BR
standard, brown

OSMDLX-BK
deluxe, padded
shoulder, black

OSMDLX-BR
deluxe, padded
shoulder, brown

BANJO STRAPS

60 mm (2.36") width, up to 1300 mm (51.18") length



OBJS-BK
banjo strap standard,
genuine suede
leather,
carabiner (2x)

OBJSDLX-BK
banjo strap deluxe,
genuine suede
leather, padded
carabiner (2x)





OCST-1BK

MULTI-MODE SOUNDHOLE TUNER OCST-1BK

PRE-INSTALLED MODES FOR CHROMATIC - UKULELE - GUITAR - BASS!



Blue backlight - not in tune



Green backlight - in tune

The OCST-1BK multi-mode soundhole tuner was designed specifically for acoustic instruments:

- Discreet and easy to install/remove
- Piezo equipped soundhole clip
- Quick change mode selector
- Easy-to-read 2-color display (blue/green)
- In tune - backlight illuminates fully green!
- Rubberized shockproof housing
- Incl. battery (coin cell, TYPE CR2032)

HEADSTOCK TUNER OCCT-1BK



OCCT-1BK



Blue backlight - not in tune



Green backlight - in tune

The OCCT-1BK is a clip-on tuner of the newest generation and comes packed with all the practical features needed:

- Sensitive sensor - tunes in noisy environment
 - One-handed swivel clamp
 - Large, easy-to-read 2-color display (blue/green)
 - In tune - backlight illuminates green!
 - Rubberized shockproof body
 - Attractive 360 degree rotating design
- FEATURES: Ukulele, bass, guitar, violin & chromatic pre-installed modes
 COLOR: black
 • Incl. battery (coin cell, TYPE CR2032)



OCAT-2BK



HEADSTOCK TUNER OCAT-2BK

The OCAT-2BK is a tuner and metronome, all in one. Mic and vibration sensor built-in to use anywhere. Fully chromatic and calibratable (410-490 Hz). Flat tuning up to 4 semitones. Built-in VISUAL metronome.

- Incl. battery (coin cell, TYPE CR2032)



SEADEVIL

PEDAL TUNER SEADEVIL

LET THERE BE LIGHT... on your pedal board. The first pedal board tuner with USB connectable LED lights (included!)

PEDAL TUNER

- Tuning range: A0 (27.5 Hz) - C8 (4,186 Hz)
- Accuracy: +/- 1 cent
- Calibration: 436-445 Hz (1 Hz step)
- Flat modi: b, bb, bbb
- Fully chromatic
- Indicator: 39 seg FND & 1LED
- Input: 6.3 mm (1/4") input jack & USB for light
- Output: 6.3 mm (1/4") output jack (true bypass)
- Power: 9V DC adapter (not included - ORTEGA OPS9500 recommended)
- Dimensions: 112 x 60 x 30 mm
- Weight: 250g net.

USB LIGHTS (LED)

- Turn on automatically when connected to pedal tuner via USB port



LED lights



USB port



Pedal tuner





DIGITAL WIRELESS SYSTEM



ODWS-1

DIGITAL WIRELESS SYSTEM | ODWS-1



Included



Plug directly into an amplifier



Plug into a pedal tuner

The Ortega Digital Wireless System features 2.4 Ghz digital technology and broadcasts incredible crystal-clear audio quality. Ready to use in seconds the system offers four operating channels (A, B, C, D), power/charge indicator and a rechargeable, built-in battery (+2500 charging cycles). The latency of < 5 ms and a full range frequency coverage of 20 Hz - 20 kHz secures great, detailed and real time sound. The ODWS-1 supports most active & passive systems as well as acoustic piezo devices*.

The ODWS-1 Digital Wireless System:

- 2.4 GHz ISM worldwide
- Up to 30 meters (100 ft.) of range without any dropout**
- 4 channels
- Up to 4 systems simultaneously
- Rubberized SHOCKPROOF housing
- 24 bit/48 kHz uncompressed digital transmission
- Easy to start in seconds - plug & play
- Auto-standby (sleep mode) after 10 seconds when there is no signal
- One transmitter can serve multiple receivers
- Rechargeable via USB (cable included!)
- Up to 5 hours use on a single charge
- Appx. 225° adjustable jack to fit almost every instrument
- 2.4 GHz technology is permission free/approved for the use in America (North and South), Europe, Asia and Australia***

Includes:

- 1x Transmitter (black)
- 1x Receiver (orange/black)
- 1x USB double head charger cable

* Some high output active systems, especially active acoustic piezos might not match well with 2.4 GHz systems.

** Open field, depends on RF environment, reflections, interference and absorption. Keep distance from WIFI router.

*** Present legislation, please inform yourself about possible changes.





CABLES

INSTRUMENT CABLES - TOUR SERIES W/ PVC JACKET

ORTEGA GUITARS high performance TOUR Series Instrument Cables are designed for the rough daily routine of touring. With an 8 mm diameter, these cable offer perfect signal transmission. The electric plated zinc alloy shell equipped connectors are covered with an inner epoxy resin insulation.

For a perfect and noiseless instrument change the connectors are equipped with MUTEPLUGS muting the signal during plugging in and unplugging.



MUTEplug

OTCI-xx

INSTRUMENT CABLE MUTEPLUG STRAIGHT/ANGLE

1/4" (6.3 mm) MUTEPLUG jack, PVC jacket, conductive PE shield, black

OTCI-10 10 ft (3.0 m), 0.8 q

OTCI-15 15 ft (4.5 m), 0.8 q

OTCI-20 20 ft (6.0 m), 0.8 q

OTCI-30 30 ft (9.0 m), 0.8 q



MUTEplug

OTCIS-xx

INSTRUMENT CABLE MUTEPLUG STRAIGHT/STRAIGHT

1/4" (6.3 mm) MUTEPLUG jack, PVC jacket, conductive PE shield, black

OTCIS-10 10 ft (3.0 m), 0.8 q

OTCIS-15 15 ft (4.5 m), 0.8 q

OTCIS-20 20 ft (6.0 m), 0.8 q

OTCIS-30 30 ft (9.0 m), 0.8 q

INSTRUMENT CABLES - ECONOMY SERIES W/ BRAIDED NYLON JACKET

ORTEGA GUITARS Economy Series Instrument & Patch Cables offer quality design and sound for all live & studio environments. Reliable & durable, our cables are developed to last and deliver the best balance between performance and players equipment.

- Custom designed with an extra thick O.D. (outside diameter) of 8 mm
- Extra thick braided nylon jacket avoids annoying tangles and minimizes handling noise
- 24 Gauge AWG (American Wire Gauge) with 95% OCC copper braided shielding for flexibility and to minimize interference
- High grade industry standard connectors with heat shrunk sleeves for additional strain relief

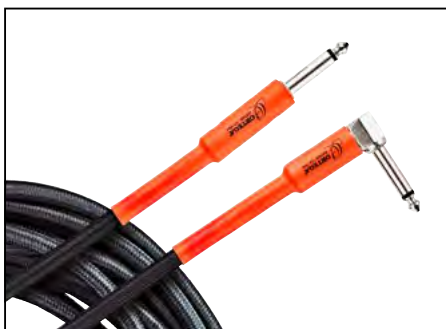

OECI-xx

INSTRUMENT CABLE STRAIGHT/ANGLE

1/4" (6.3 mm) jack/jack, braided nylon over PVC, black

OECI-5 5 ft (1.5 m), 0.8 q

OECI-10 10 ft (3.0 m), 0.8 q

OECI-15 15 ft (4.5 m), 0.8 q

OECI-20 20 ft (6.0 m), 0.8 q

OECI-30 30 ft (9.0 m), 0.8 q



OECIS-xx

INSTRUMENT CABLE STRAIGHT/STRAIGHT

1/4" (6.3 mm) jack/jack, braided nylon over PVC, black

OECIS-5 5 ft (1.5 m), 0.8 q

OECIS-10 10 ft (3.0 m), 0.8 q

OECIS-15 15 ft (4.5 m), 0.8 q

OECIS-20 20 ft (6.0 m), 0.8 q

OECIS-30 30 ft (9.0 m), 0.8 q



OTCPA-04



OPU20-OTCPA-04

PATCH CABLE PANCAKE STYLE

1/4" (6.3 mm) „PANCAKE“ jacks w/gold tip, PVC jacket, conductive PE shield, black

OTCPA-04 0.4 ft (13 cm), 0.65 q

PU20-OTCPA-04 PACKING UNIT of 20x OTCPA-04 incl. **attractive Display Bowl**



OECPA3-06

PATCH CABLE ANGLE/ANGLE

1/4" (6,3 mm) jack/jack, braided nylon over PVC, black

OECPA3-06 0.6 ft (18 cm), 0.8 q, pack of 3

LOUDSPEAKER CABLE - TOUR SERIES

ORTEGA LOUDSPEAKER CABLES are manufactured with the highest grade materials in the industry. The copper wire meets AWG rating specifications. The all-metal, nickel plated classic connectors provide durability and exceptional performance.



OTCLS-5JJ



LOUDSPEAKER CABLE OTCLS-5JJ

Ortega Tour Series Speaker Cables – The premium connection for your sound.

- 5 feet | 1.5 m length
- True 12AWG (American Wire Gauge) rated
- Professional Quality and Construction
- Extra thick 10.0 mm Durable & Flexible Rubber Jacket
- 2x Hook and Loop Wrap (reusable) included

MICROPHONE CABLES - ECONOMY SERIES W/ BRAIDED NYLON JACKET

ORTEGA GUITARS Economy Series Instrument, Microphone & Patch Cables offer quality design and sound for all live & studio environments. Reliable & durable, our cables are developed to last and deliver the best balance between performance and players' equipment.

- Custom designed with an extra thick O.D. (diameter) of 8 mm
- Extra thick braided nylon jacket avoids annoying tangles and minimizes handling noise
- 24 Gauge AWG (American Wire Gauge) with 95 % OCC copper braided shielding for flexibility and to minimize interference
- High grade industry standard XLR & JACK connectors with heat shrunk sleeves for additional strain relief



OECM-xxJX



OECM-xxXX



MICROPHONE CABLE 1/4" (6.3 mm) JACK/XLR FEMALE

Braided nylon sleeve over PVC jacket, black

OECM-10JX 10 ft (3.0 m), 0.8 q

OECM-20JX 20 ft (6.0 m), 0.8 q

OECM-30JX 30 ft (9.0 m), 0.8 q

MICROPHONE CABLE XLR MALE/XLR FEMALE

Braided nylon sleeve over PVC jacket, black

OECM-10XX 10 ft (3.0 m), 0.8 q

OECM-20XX 20 ft (6.0 m), 0.8 q

OECM-30XX 30 ft (9.0 m), 0.8 q



STRINGS

4STRING UKULELE



UWNY-4-SO



UWNY-4-CC



UWNY-4-TE



UWNY-4-BA

ORTEGA GUITARS white nylon series ukulele strings are developed in cooperation with the world famous ukulele string maker AQUILA and manufactured in Italy. The combination of materials used are designed to deliver the perfect combination of warm yet punchy tone.

SOPRANO:

UWNY-4-SO .026/.037/.032/.024

CONCERT:

UWNY-4-CC .027/.038/.032/.024

TENOR:

UWNY-4-TE .028/.038/.032/.026

BARITONE:

UWNY-4-BA w/w/.032/.027

6 & 8STRING TENOR UKULELE



UNY-6-TE



UNY-8-TE

ORTEGA Nylon series ukulele strings are created in cooperation with the world-famous ukulele string maker AQUILA and manufactured in Italy. The combination of materials used is designed to deliver the perfect combination of warm yet punchy tone. Precise intonation, tuning stability and comfortable playability are the cornerstones of ORTEGA ukulele strings.

Custom made for 6 & 8string tenor scale.

UNY-6-TE .027/.037/.019/.033/.040/.025

UNY-8-TE .041/.026/.037/.019/.031/.031/.025/.025

6STRING GUITARLELE



GLNY-6

ORTEGA Guitarlele strings are created in cooperation with the world famous ukulele string maker AQUILA and manufactured in Italy. The combination of materials used is designed to deliver the perfect combination of warm yet punchy tone. Precise intonation, tuning stability and comfortable playability are the cornerstones of ORTEGA Guitarlele strings.

Perfect for 420 mm – 440 mm scale.

GLNY-6 .041/.033/.027/.038/.032/.026

8STRING NYLON GUITAR



OCTA-8NS

8string nylon string guitar set – Made in Germany. Custom made of the finest materials, with great precision and HANDCRAFTED by experts. Optimized for 690 mm scale. E/B/E/A/d silver plated copper wound on nylon silk g/b/e – nylon rectified.

OCTA-8NS .029/.032/.041/.031/.037/.046/.060/.083

4STRING ACOUSTIC BASS



ODW-4

Custom made in Germany for short scale acoustic basses (up to 25"). Silver plated copper wound on nylon silk.

ODW-4 .043/.059/.071/.080 fully balanced strings 5.5 kg (12.12 Lbs)

Custom developed for D-Walker bass!

6STRING GUITAR



ATG44NM



ATG44NH



ATMOSPHERE green – a revolutionary step in achieving the ultimate Organic Sound! ORTEGA Guitars atmosphere green strings are created and manufactured in Italy. By replacing the usually oil based treble strings with a newly developed nylon material which is made from 100 % plant-based products. Our Atmosphere Green strings deliver a perfect combination of bright, warmth, punchy tone and incredible projection. Precise intonation and long-lasting tuning stability add to their exceptional playability. Our small but important contribution for a cleaner and greener planet.

ATG44NM (MEDIUM)

Diameter	.042 w	.034 w	.028 w	.040	.032	.028
----------	--------	--------	--------	------	------	------

ATG44NH (HARD)

Diameter	.043 w	.035 w	.028 w	.041	.033	.029
----------	--------	--------	--------	------	------	------

6STRING GUITAR



ATB44NM



ATB44NH



ATMOSPHERE balance – a revolutionary step in achieving the ultimate BALANCED TONE! Through our intensive engineering process, we calculate the windings, thickness, and core of the 3 bass strings. This process, creates additional flexibility which increases vibration and resonance, ultimately delivering an extraordinary brightness and crystal-clear tonal experience. This creates a fully balanced string which delivers superior feel and tone. All Ortega professional nylon strings are proudly produced with traditional German craftsmanship.

ATB44NM (MEDIUM)

Item-No.	ATB44NM-E6	ATB44NM-A5	ATB44NM-D4	ATB44NM-G3	ATB44NM-B2	ATB44NM-E1
Diameter	.043 w	.035 w	.029 w	.039	.031	.028
Tension (lbs)	13.89	13.89	13.67	11.46	11.68	15.87

ATB44NH (HARD)

Item-No.	ATB44NH-E6	ATB44NH-A5	ATB44NH-D4	ATB44NH-G3	ATB44NH-B2	ATB44NH-E1
Diameter	.044 w	.036 w	.030 w	.039	.031	.028
Tension (lbs)	14.77	14.77	14.99	11.46	11.68	15.87

Single strings available





PICKS

20 ORTEGA PICKS – packing unit



PU20-OGPOR-M

Ortega PU20-OGPOR-M contains 20-piece pack of guitar picks in original Ortega orange featuring a 0.71 mm, medium thickness for great and playability. A light "sandy" surface provides a firm comfortable grip.

ORTEGA FELT PICKS – SOFT & HARD



OGP-F-S3
OGP-F-H3

Custom designed especially for Ukulele & Nylon String Guitar. Made from high quality compressed synthetic wool, rounded tip, anti-slip "grip hole" – pack of 3

OGP-F-S3 3 mm thickness, SOFT
Color: light grey

OGP-F-H3 4 mm thickness, HARD
Color: light brown

ORTEGA PICKS

Guitar picks – Made in Germany. Produced with highest industry standard – pack of 10

OGP-BP-T10
blue pearl, thin

OGP-BP-M10
blue pearl, medium

OGP-BP-H10
blue pearl, heavy

OGP-WP-T10
white pearl, thin

OGP-WP-M10
white pearl, medium

OGP-WP-H10
white pearl, heavy

OGP-TO-T10
tortoise, thin

OGP-TO-M10
tortoise, medium

OGP-TO-H10
tortoise, heavy



OGP-BP
OGP-WP
OGP-TO

ORTEGA UKULELE LEATHER PICKS

Soft and extra large REAL LEATHER PICKS – especially designed for ukulele players but also perfect to use with any Nylon String Guitar.

- Warm soft tones with no loss of volume

UKEPICK-ASS Assorted pack of 3 black/white/red



UKEPICK-ASS

PERFECT FOR ANY NYLON STRING GUITAR, TOO!

ORTEGA WOODEN PICKS – CURVED

STANDARD, SHARP TIP, CURVED THUMP GRIP – HANDMADE FROM REAL WOOD
2.5 mm thickness.

Made from high quality real wood, sharp tip.

OGPW-OV2 ovangkol wood, pack of 2

OGPW-PD2 padouk wood, pack of 2

OGPW-SW2 sandalwood, pack of 2

OGPW-CH2 chacate wood, pack of 2

OGPW-MIX4 1x ovangkol, 1x padouk, 1x sandal, 1x chacate – pack of 4



OGPW-OV2
OGPW-PD2
OGPW-SW2
OGPW-CH2

OGPW-MIX4

ORTEGA WOODEN PICKS – FLAT

TRIANGLE XL, SHARP TIP, FLAT – HANDMADE FROM REAL WOOD
2.0 mm thickness.

Made from high quality real wood, sharp tip.

OGPWXLF-OV2 ovangkol wood, pack of 2

OGPWXLF-PD2 padouk wood, pack of 2

OGPWXLF-SW2 sandalwood, pack of 2

OGPWXLF-CH2 chacate wood, pack of 2

OGPWXLF-MIX4 1x ovangkol, 1x padouk, 1x sandal, 1x chacate – pack of 4



OGPWXLF-OV2
OGPWXLF-PD2
OGPWXLF-SW2
OGPWXLF-CH2



OGPWXLF-MIX4

FLEX TECH PICKS – SOFT & HARD

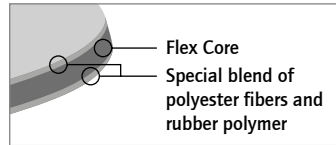

OGP-FTS
OGP-FTH

IDEAL FOR UKULELE & NYLON STRING GUITARS

Ortega Guitars FLEX TECH PICKS are handmade in the USA from a flexible composite felt which provides unrivaled tone and performance. Ideal for Ukulele, Nylon String Guitars, Acoustic Bases and many other stringed instruments.

OGP-FTS

SOFT, FLEX TECH with FLEX CORE TECHNOLOGY, 2.5 mm/0.984" goldenrod, pack of 4

OGP-FTH

HARD, FLEX TECH with FLEX CORE TECHNOLOGY, 3.8 mm/1.496" black, pack of 4



OGPST12-050
OGPST12-060
OGPST12-073



OGPST12-088
OGPST12-100
OGPST12-120



12
PACK

S-TECH PICKS

PACK OF 12 PICKS

Made in the USA, Ortega Guitars S-Tech picks combine the highest quality materials with traditional craftsmanship and modern production techniques to produce a professional guitar pick with exceptional durability, a grip friendly granular surface, and dynamic response - pack of 12.

OGPST12-050

pink, 0.50 mm

OGPST12-060

green, 0.60 mm

OGPST12-073

sand, 0.73 mm

OGPST12-088

blue, 0.88 mm

OGPST12-100

red, 1.00 mm

OGPST12-120

black, 1.20 mm

DISPLAY WITH 216 PICKS

Attractive, 100% recyclable hard paper sales display with 216x ORTEGA S-TECH PICKS included.

OGPSD-216

- 1x OGPST36-050 pink, 0.50 mm
- 1x OGPST36-060 green, 0.60 mm
- 1x OGPST36-073 sand, 0.73 mm
- 1x OGPST36-088 blue, 0.88 mm
- 1x OGPST36-100 red, 1.00 mm
- 1x OGPST36-120 black, 1.20 mm

REFILL PACKS

Perfect to refill the OGPSD216 sales box or have a safety stock.

Each refill pack contains 36 picks.

- OGPST36-050** pink, 0.50 mm
- OGPST36-060** green, 0.60 mm
- OGPST36-073** sand, 0.73 mm
- OGPST36-088** blue, 0.88 mm
- OGPST36-100** red, 1.00 mm
- OGPST36-120** black, 1.20 mm



OGPSD-216



STRAP LOCKS & TUNING MACHINES

STRAP LOCK



OSLOPRO-CR



OSLOPRO-GB



OSLOPRO-GO

Professional Strap Locks included one extra pair of screws/pins
2 Instruments - only one system.
Safely connects your guitar/bass strap with two of your instruments. Includes 1 pair of strap locks with washers, nuts & 2 sets of strap buttons with installation screws.

OSLOPRO-CR

Chrome, bright incl. FREE 2nd pair of screws/pins

OSLOPRO-GB

Gloss black incl. FREE 2nd pair of screws/pins

OSLOPRO-GO

Gold, bright incl. FREE 2nd pair of screws/pins

TUNING MACHINES OTM-STUDENT



OTM-STUDENT

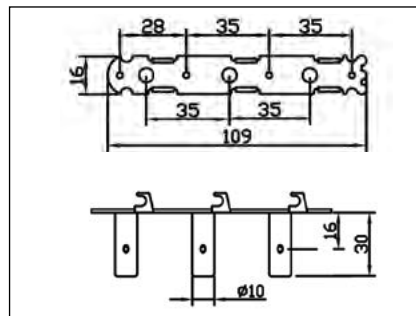

RATIO: 14:1

3+3 tuning machine set with chrome plated baseplate, black nylon rollers and black pearl-style buttons.

Original part of the Ortega Student Series.

TUNING MACHINES



OTM-FAMILYNT

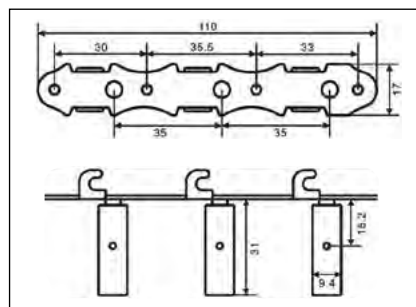

OTM-FAMILYNT

RATIO: 14:1

3+3 tuning machine set with chrome plated baseplate, white nylon rollers and white pearl-style buttons.

Original part of the Family Series - natural.

OTM-FAMILYBK

RATIO: 14:1

3+3 tuning machine set with golden baseplate, black nylon rollers and black pearl-style buttons.

Original part for the Family Series (black /R221BK).

OTM-FAMILYPRO

RATIO: 14:1

3+3 tuning machine set with golden baseplate, white nylon rollers and white pearl-style buttons.

Original part of the Family Pro Series.



OTM-FAMILYBK



OTM-FAMILYPRO

TUNING MACHINES OTMSTD-GOWH



OTMSTD-GOWH

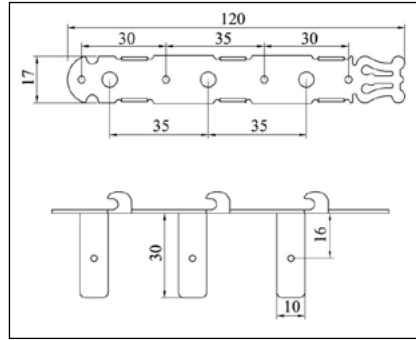

RATIO: 14:1

Golden lyra-design tuning machines with white nylon rollers and white pearl buttons

TUNING MACHINES



OTMDLX-GOBK



OTMDLX-BKBK

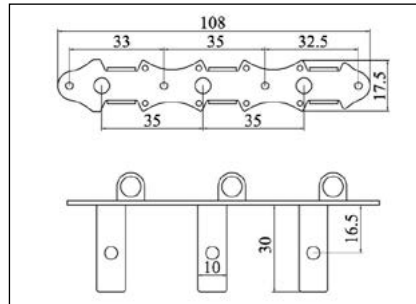
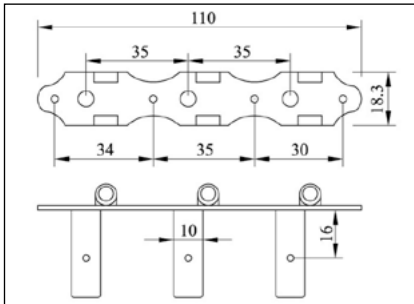

OTMDLX-GOBK

RATIO: 14:1

Golden baseplate tuning machines with black nylon rollers and black ebony-style buttons

OTMDLX-BKBK

RATIO: 14:1

Black baseplate tuning machines with black nylon rollers and black ebony-style buttons

TUNING MACHINES OTMPRIVATE



OTMPRIVATE

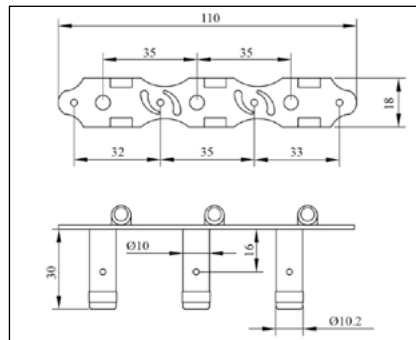

RATIO: 18:1

Brushed brass baseplate tuning machines with plated steel worm shafts, black nylon rollers and black ebony-style buttons

TUNING MACHINES OTMPREMIUM



OTMPREMIUM

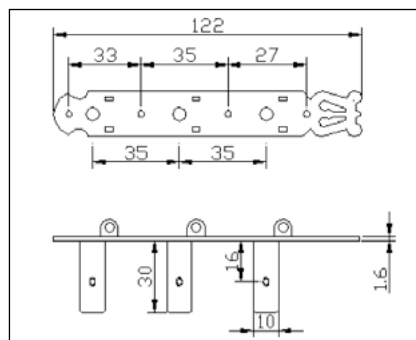

RATIO: 18:1

Brushed brass Lyra-design baseplate tuning machines with black plated steel worm shafts, black nylon rollers, pearl inlays and black acrylic-style buttons.



CABLES & POWER

DC POWER SPLITTER CABLES



ODC4

ODC6

ODC8

The Ortega ODC4/ODC6/ODC8 are perfect to use with 9V & 18V power supplies. Feeds 4, 6 or 8 devices simultaneously.

ODC4 4head version,
1.40 m/4.6 ft cable length

ODC6 6head version,
2.00 m/6.5 ft cable length

ODC8 8head version,
2.70 m/8.9 ft cable length

CABLE LENGTH OF 3 METERS/9.8 FEET!



OPS9500EU

(most European countries)

OPS9500US

(USA & Canada)



OPS9500JP

(Japan)

OPS9500UK

(Great Britain)

POWER SUPPLY

The **OPS9500** power supply series is intended for the use with any effect pedals (analog or digital) requiring 9V and good for up to 500 mA.

Special feature:

Cable length of 3 meters /9.8 feet!

- INPUT POWER 100-240 VAC, 50/60 Hz
- OUTPUT POWER 9V DC/500 mA

Ortega power supplies are CE (EUROPE) & UL/class6 (USA) & PSE (Japan) tested and certified.



OER-CR2032/2



Type CR2032

BATTERIES OER-CR2032/2

2pack of 3V coin cell batteries, Type CR2032 (recommended for all Ortega MagusUke and MagusUkePRO preamps and tuners)

ACOUSTIC & NYLON STRING GUITAR SYSTEMS



MagusGO

Active output jack w/ sound hole control preamp system*

- No need to make a side cut, easy to install
- Powered by 9V battery
- Setup with VOLUME and TONE control (designed for inner soundhole attachment)
- Includes piezo pickup (guitar), battery pocket and cable clamp

UKULELE SYSTEMS



MagusUkeGO

Active output jack w/ sound hole control preamp system*

- No need to make a side cut, easy to install
- Powered by 9V battery
- Setup with VOLUME and TONE control (designed for inner soundhole attachment)
- Includes a flexible pickup, battery pocket and cable clamp



MagusPRO/G

Professional side mount onboard active preamp system*

- Built-in tuner (mutes output signal when in use)
- 2 color display
- Seamless, separate VOLUME control
- 3 band EQ featuring single BASS, MIDDLE & TREBLE controls
- Phase turn button
- Powered by 9V battery
- Separate battery compartment with output jack
- Includes piezo pickup (guitar), output/battery compartment device and cable clamp

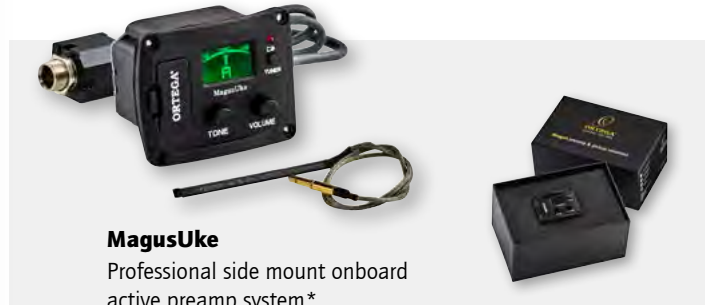

MagusUke

Professional side mount onboard active preamp system*

- Built-in tuner (mutes output signal when in use)
- 2 color display
- TONE control & VOLUME control, FREQUENCY control
- Easy to reach battery compartment
- Uses 2x CR2032 coin cells (we recommend Ortega OER-CR2032/2)
- Includes piezo pickup (ukulele), output jack and cable clamp

ACOUSTIC BASS SYSTEM



MagusPRO/B

Professional side mount onboard active preamp system*

- Built-in tuner (mutes output signal when in use)
- 2 color display
- Seamless, separate VOLUME control
- 3 band EQ featuring single BASS, MIDDLE & TREBLE controls
- Phase turn button
- Powered by 9V battery
- Separate battery compartment with output jack
- Includes piezo pickup (bass), output/battery compartment device and cable clamp



MagusUkePRO

Professional side mount onboard active preamp system*

- Built-in tuner (mutes output signal when in use)
- 2 color display
- 3 band EQ featuring single BASS, MIDDLE & TREBLE controls
- Separate battery compartment with output jack
- Uses 2x CR2032 coin cells (we recommend Ortega OER-CR2032/2)
- Includes piezo pickup (ukulele), output/battery compartment device and cable clamp

*For best results and to avoid irreparable damage to your instrument please consult a specialized guitar technician proper installation.



USEFUL HELPERS

3 HEAD STRING WINDER & CUTTER



UKULELE



GUITAR



BASS



OSWC-3H

A practical tool to make changing strings effortless. The Ortega Guitars 3 Head Multi-tool is a 3-in-1 tool for ukulele, guitar and bass maintenance: peg winder, bridge pin puller, and string cutter.

The OSWC-3H comes with 3 interchangeable heads for ukulele, guitar and bass. Change the strings on almost any instrument with only one tool. Made of high-quality Japanese steel for highest durability.

STRING CUTTER

Made out of hardened JAPANESE STEEL the OSWC-3H provides superior strength and long-lasting durability and cuts the wire with precision.

PIN PULLER

Quick and easy string changes are guaranteed with the built-in bridge pin puller. The wide contact surface of the bridge-pin puller helps to better protect your bridge from marks.

STRING WINDER

The OSWC-3H comes with 3 interchangeable heads for ukulele, guitar and bass – the perfect fit for all your stringed instruments.



VE40-OSW-STD



OSW-STD

STRING WINDER

String replacement in a few seconds with this classic string winder. The notched head removes bridge pins quickly and safely. Perfect shaped for nylon string & acoustic guitars.

OSW-STD

Classic string winder, single

VE40-OSW-STD

Useful display box – filled with 40x OSW-STD



FEX4



FEX5



Only a few minutes for best results



Lockable pistons for more exercise possibilities



FINGER TRAINER

The original Ortega Guitars FEX4 & FEX5 are advanced pocket-sized, light weight training tools for different needs. FEX4 & FEX5 helps you to build-up strength for the entire hand and forearm.

Adjustable tension for each finger

FEX4 3-7 lbs (appx. 1.3-3.2 kg), 4 pistons

FEX5 3-8.5 lbs (appx. 1.3-3.9 kg), 5 lockable pistons for more training possibilities.

Train and maintain strength for your fingers, palm and forearms, supports reaction speed, flexibility and other high difficult action training.

PERFECT PRE-GIG WARM-UP TOOL, PRE-CLIMBING EXERCISE TOOL /SPORTS SUPPORT & MEDICAL REHABILITATION TOOL.*

FEX4 individual adjustable tension for 4 available pistons

FEX5 individual adjustable tension for 5 available pistons

* Ask your doctor IN ADVANCE for medical rehabilitation use.

CABLE TIES PACK OF 10



OCBT-10

Ortega Cable ties keep your cables coiled up and well organized for tidy storage. Works with all instrument, microphone and power cables.

OCBT-10
Cable ties, hook & loop
0.6 x 0.065 ft
(18 cm x 2 cm), orange,
pack of 10

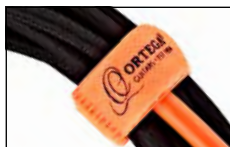

ELIMINATOR100
ELIMINATOR86



FITS ALMOST ALL
ACOUSTIC INSTRUMENTS!

ELIMINATOR

Feedback Eliminator/Soundhole Cover
Simply place the ELIMINATOR into your acoustics' soundhole and start your feedback-free performance. Designed to play at a far greater volume on stage without the risk of unwanted howling or feedback. Safe for the instruments' finish due to its soft rubber.

ELIMINATOR100
100 mm (4") diameter,
fits most steel strings & acoustic basses

ELIMINATOR86
86 mm (3.38") diameter,
fits most nylon & classical guitars

ORTEGA MUSIC LIGHTS



OML-S

OML-D

RECHARGEABLE!
NO MORE BATTERIES -
LESS WEIGHT!

CLIP ON LED MUSIC LIGHTS

Perfect for travel, music stand lighting, desk and computer or reading.

- Strong and bright LEDs (4/each head)
- Rechargeable via USB!
- Two settings - bright (100%) & dim (50%)
- Adjustable gooseneck(s) for optimal lightning
- Easy to use, strong clamp for mounting
- Easy to install and remove - no tools needed!
- USB charger cable included!

OML-S: SINGLE neck - 8h+ on a single charge
OML-D: DOUBLE neck - 6h+ on a single charge

FRETBOARD OIL OLEM



OLEM

Lemon oil - cleaning, conditioning & restoring
The original Ortega Guitars Lemon Oil is perfect to remove dirt, wax and grease from dark wooden surfaces incl. unfinished fretboards.*
60 ml (2.1 fluid oz)

* For best results we recommend you use original Ortega polish cloth OPC-GR/LG, OPC-LY/LB or OPC-XXL

CLEANER OGC1



OGC1

Original Ortega guitar cleaner, made in Germany.
pH neutral with a decent cedar note. Perfect for gloss, open pore and satin finish (do not use for French polish).

OPC-GR/LG PACK OF 2!



OPC-LY/LB PACK OF 2!



OPC-XXL



EXTRA LARGE!

POLISH CLOTH

Professional, extra soft microfiber polishing/cleaning cloth with serrated edge. Features embossed Ortega logo.

OPC-GR/LG - pack of 2! (green/light grey)
Dimensions: 29 cm x 24 cm (11.5" x 9.5")

OPC-LY/LB - pack of 2!
(light yellow/light brown)
Dimensions: 29 cm x 24 cm (11.5" x 9.5")

OPC-XXL - extra large size (light yellow)
Dimensions: 50 cm x 40 cm (19.70" x 15.75")



CARE

PROTECTION FOILS



OERP



OBCF

**NO GLUE!
ELECTROSTATIC
FEATURES**

Electrostatic reusable foils. The perfect protection against dings & scratches. Clear transparent. To use on gloss finishes only. Removable any time!

OERP

Pickguard for top, transparent

OBCF

Back cover foil, transparent



OPG-FLAM1

**PERMANENT
GLUE!**



OERP-FLAM1

**NO GLUE!
ELECTROSTATIC
FEATURES**

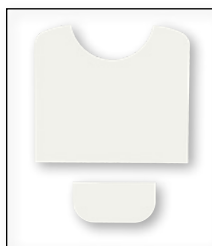

Transparent scratch plates for acoustic guitars protect the top surface against scratches and dings. Clear transparent foil for Flamenco Style playing.

OPG-FLAM1

Permanent glue on FULL TOP foil set.

Usable on gloss & satin finishes. Self-gluing foil for permanent installation. String change protection foil included.

OERP-FLAM1

Reusable electrostatic FULL TOP foil set.

Usable on gloss finishes only. Holds with electrostatic features. String change protection foil included.



OPG-FLAM2

**PERMANENT
GLUE!**



OERP-FLAM2

**NO GLUE!
ELECTROSTATIC
FEATURES**

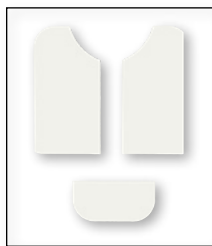

OPG-FLAM2

Permanent glue on DIVIDED foil set.

Usable on gloss & satin finishes. Self-gluing foil for permanent installation. String change protection foil included.

OERP-FLAM2

Reusable electrostatic DIVIDED foil set.

Usable on gloss finishes only. Holds with electrostatic features. String change protection foil included.

WOODEN UKULELE PICKGUARDS



OWPSC-EB
OWPTB-EB

OWPSC-FMA
OWPTB-FMA

OWPSC-WN
OWPTB-WN



Choose your personal style

EBONY - FLAMED MAPLE - WALNUT

Made from REAL wood, the Ortega ukulele pickguards light up your instrument and makes your ukulele stand out with extra flair. Easy to put on with already installed adhesive foil. Shaped for Soprano, Concert, Tenor & Baritone size.

SOPRANO & CONCERT sound hole diameter appx. 55 mm

OWPSC-EB	EBONY
OWPSC-FMA	FLAMED MAPLE
OWPSC-WN	WALNUT

TENOR & BARITONE sound hole diameter appx. 58 mm

OWPTB-EB	EBONY
OWPTB-FMA	FLAMED MAPLE
OWPTB-WN	WALNUT

HUMIDIFIERS



HUMIGT-BK



HUMIGT-SV



HUMIUUK-BK



HUMIUUK-SV



Suspend between the strings - no body touch

Humidifying wooden acoustic instruments is the most underrated topic, but the lack of humidification is the number one cause of repairs. The ORTEGA humidifiers are the most easiest and simplest way to maintain your instruments in best humidity condition.

- Ortega humidifiers suspend between the strings and never touch any part of the instruments body
- Easy to refill sponge style system
- Non-drip design - releases moisture (if needed for instrument) evenly and slowly to maintain the proper humidity level
- Includes a syringe for water

Sound hole humidifier for **ACOUSTIC GUITAR**

HUMIGT-BK BLACK

HUMIGT-SV SILVER

Sound hole humidifier for **UKULELE**,
1/4 & 1/2 size instruments

HUMIUUK-BK BLACK

HUMIUUK-SV SILVER

HUMIBUSTER



HUMIBUSTER100
HUMIBUSTER80



Includes a syringe for
water refill

Feedback killer & Humidifying system. Permanent feedback cover for acoustic instruments with the additional function of a humidifying system. Equipped with a sponge and pores, the system maintains the relative humidity of your instrument and protects the wood from drying out.

HUMIBUSTER100

100 mm (4") diameter, fits most acoustic guitars and acoustic basses

HUMIBUSTER80

85 mm (3.35") diameter, fits most classical guitars





BAGS SOFT CASES



GUITAR



UKULELE



SOFT CASES

Travel in style with hard-case like protection with significantly less weight!

Ortega premium SOFT CASES are made with a canvas/cotton surface and real suede leather inlays. The 22 mm (0.86") soft sponge padding is supported by a 5 mm (0.20") hardened PE plastic frame. A plush black velvet material interior includes a neck brace with Velcro safety straps. The exterior features heavy duty zippers, comfortable, adjustable shoulder straps, a suede leather covered handle and two front compartments (one for ukulele sizes).

Available in 3 attractive colors:

MOCCA (**MO**) - OCEAN BLUE (**OC**) - BORDEAUX WINE (**BX**)



BANJO

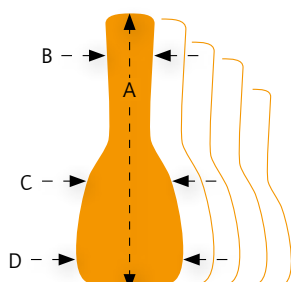

DIMENSIONS

ACOUSTIC DREADNOUGHT	A	B	C	D	Height
OSOCADN-xx dreadnought	107.0 cm 42.13"	14.0 cm 5.51"	33.0 cm 12.99"	42.0 cm 16.54"	13.0 cm 5.12"
CLASSICAL	A	B	C	D	Height
OSOCACL34-xx classic 3/4 size	92.5 cm 36.42"	12.0 cm 4.72"	25.0 cm 9.84"	36.5 cm 14.37"	12.0 cm 4.72"
OSOCACL-xx regular classic size	103.5 cm 40.75"	12.0 cm 4.72"	31.0 cm 12.2"	39.0 cm 15.35"	11.5 cm 4.53"
UKULELE	A	B	C	D	Height
OSOCAUK-SO-xx soprano	55.0 cm 21.65"	9.0 cm 3.54"	13.5 cm 5.31"	19.0 cm 7.48"	9.0 cm 3.54"
OSOCAUK-CC-xx concert	64.0 cm 25.2"	10.0 cm 3.94"	14.5 cm 5.71"	22.0 cm 8.66"	9.5 cm 3.74"
OSOCAUK-TE-xx tenor	67.5 cm 26.57"	10.0 cm 3.94"	16.0 cm 6.3"	23.0 cm 9.06"	10.0 cm 3.94"
BANJO	A	B	C	D	Height
OSOCABJ-xx classic 3/4 size	92.5 cm 36.42"	12.0 cm 4.72"	25.0 cm 9.84"	36.5 cm 14.37"	12.0 cm 4.72"

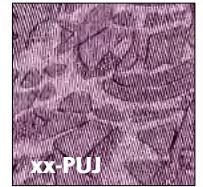
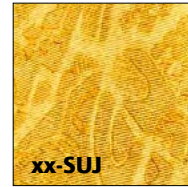
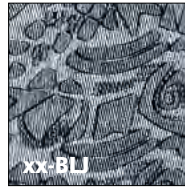

GUITAR



UKULELE



JEAN COLOR BAGS

Travel in style with great protection.

Ortega JEAN BAGS are made with a canvas/cotton surface decorated in fun stonewashed denim colors, covering a 12 mm (0.47") soft padding. A soft black nylon interior includes a neck brace with Velcro safety straps. The exterior features heavy duty zippers, comfortable, adjustable shoulder straps, and a large front storage pocket.

Available in 4 fantastic colors:

BLUE JEAN (**BLJ**) - GREEN JEAN (**GRJ**) - SUN JEAN (**SUJ**) - PURPLE JEAN (**PUJ**)

front compartment



guitar



ukulele

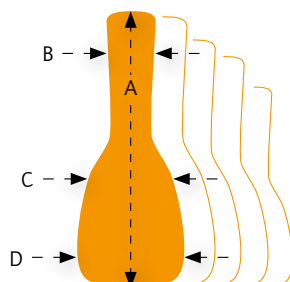

DIMENSIONS

GUITAR	A	B	C	D	Height
OGBCL-xx	108.0 cm	13.0 cm	31.0 cm	39.0 cm	14.0 cm
regular classic size	42.52"	5.12"	12.2"	15.35"	5.51"
UKULELE	A	B	C	D	Height
OUB-SO-xx	56.0 cm	10.0 cm	13.0 cm	19.0 cm	6.0 cm
soprano	22.05"	3.94"	5.12"	7.48"	2.36"
OUB-CC-xx	66.0 cm	10.0 cm	16.5 cm	23.0 cm	8.0 cm
concert	25.98"	3.94"	6.5"	9.06"	3.15"
OUB-TE-xx	69.0 cm	10.0 cm	17.5 cm	24.0 cm	8.0 cm
tenor	27.17"	3.94"	6.89"	9.45"	3.15"



BAGS ECONOMY / PRO

GUITAR BAGS ECONOMY OGBSTD-xx



OGBSTD-xx

Quality guitar bags for any budget. Made from sturdy nylon material with a 10 mm soft inside padding and heavy duty zippers. Includes a big accessory compartment (perfect size for music books) and two adjustable shoulder straps.

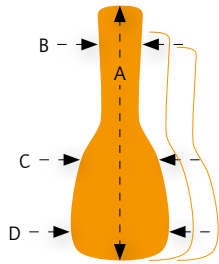

DIMENSIONS

	A	B	C	D
OGBSTD-44	105.0 cm 41.34"	14.0 cm 5.52"	32.0 cm 12.6"	40.0 cm 15.75"
OGBSTD-34	98.0 cm 38.58"	14.0 cm 5.52"	30.0 cm 11.8"	37.0 cm 14.56"
OGBSTD-12	96.0 cm 37.8"	14.0 cm 5.52"	30.0 cm 11.8"	35.0 cm 13.78"

UKULELE BAGS ECONOMY OUBSTD-xx



OUBSTD-xx

Quality guitar bags for any budget. Made from sturdy nylon material with a 10 mm soft inside padding. Includes an accessory compartment (fits an ORTEGA OPUS portable uke stand!) and two adjustable shoulder straps.

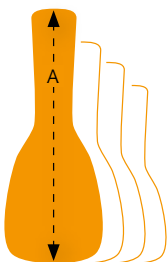

DIMENSIONS

	A (inside)
OUBSTD-SI Sopranino length	54.0 cm 21.26"
OUBSTD-SO soprano length	55.0 cm 21.65"
OUBSTD-CC concert length	62.0 cm 24.41"
OUBSTD-PINE concert length	62.0 cm 24.41"
OUBSTD-TE tenor length	68.0 cm 26.77"
OUBSTD-BA baritone length	78.0 cm 30.71"

GUITAR BAGS PRO ONB-xx



ONB-xx

Professional classic gig bags made from heavy duty nylon material. Thick padding inside, very wide neck brace with safety straps, heavy duty zippers, wide and comfortable shoulder straps (adjustable), padded handle and two accessory compartments distinguishes this exclusive bag.

DIMENSIONS

	A	B	C	D
ONB44L full size extra long	105.4 cm 41.5"	14.3 cm 5.63"	31.12 cm 12.25"	40.0 cm 15.75"
ONB44 full size	103.5 cm 40.75"	14.3 cm 5.63"	30.5 cm 12.01"	37.15 cm 14.63"
ONB34 three quarter size	94.62 cm 37.25"	14.3 cm 5.63"	26.7 cm 10.51"	35.88 cm 14.13"
ONB12 half size	88.27 cm 34.75"	14.3 cm 5.63"	23.5 cm 9.25"	32.7 cm 12.87"
ONB14 quarter size	76.84 cm 30.25"	14.3 cm 5.63"	21.6 cm 8.5"	28.25 cm 11.12"

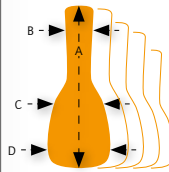

BASS BAG PRO OABB



OABB

Professional acoustic bass gig bag made from heavy duty nylon material. Thick padding inside, very wide neck brace with safety straps, heavy duty zippers, wide and comfortable shoulder straps (adjustable), padded handle and two accessory compartments distinguishes this exclusive bag. Works for up to 34" longscale.

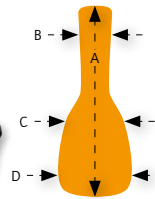

DIMENSIONS

	A	B	C	D
OABB	125.0 cm 49.2"	19.0 cm 7.48"	38.0 cm 14.96"	46.0 cm 18.11"

UKULELE BAGS PRO OUGB-xx



OUGB-xx

Professional ukulele gig bags made from heavy duty nylon material. Thick padding inside, heavy duty zippers, padded handle and an accessory compartment distinguishes this exclusive bag.

DIMENSIONS

	A (inside)
OUGB-SO soprano length	55.0 cm 21.65"
OUGB-CC concert length	62.0 cm 24.41"
OUGB-TE tenor length	68.0 cm 26.77"
OUGB-BS baritone length	78.0 cm 30.71"

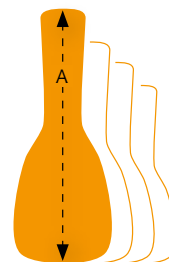



OACCSTD-DN
OCCSTD-34
OCCSTD
OCCSTD-T

OEGCSTD

OCCSTD

CASES ECONOMY

Budget friendly instrument cases in classic black vinyl finish. Flat top, 15 mm padding – covered by "coffee" velvet, accessory compartment, chrome hardware and a strong handle distinguishes these timeless cases.

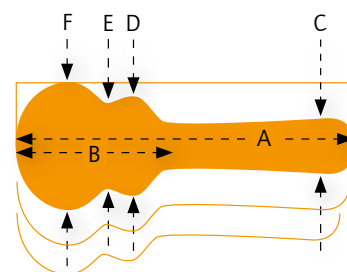

READY TO GO CASE & BACK PACK BUNDLE

OACCSTD-DN-BU
 Acoustic case "Dreadnought" INCL. pre-installed OBPS back pack strap.

OCCSTD-BU
 Regular classic case INCL. pre-installed OBPS back pack strap.

GUITAR CASES							
INNER DIMENSIONS							
ACOUSTIC	A	B	C	D	E	F	Height
OACCSTD-DN dreadnought	107.5 cm 42.32"	58.0 cm 22.83"	15.5 cm 6.1"	29.5 cm 11.61"	28.0 cm 11.02"	41.0 cm 16.14"	13.5 cm 5.31"
OACCSTD-DN-BU case and back pack strap	107.5 cm 42.32"	58.0 cm 22.83"	15.5 cm 6.1"	29.5 cm 11.61"	28.0 cm 11.02"	41.0 cm 16.14"	13.5 cm 5.31"
CLASSICAL	A	B	C	D	E	F	Height
OCCSTD-34 classic 3/4 size	98.0 cm 38.58"	47.0 cm 18.50"	12.5 cm 4.92"	25.0 cm 9.84"	23.0 cm 9.06"	35.0 cm 13.78"	11.0 cm 4.33"
OCCSTD regular classic	103.0 cm 40.55"	56.0 cm 22.05"	14.5 cm 5.71"	27.5 cm 10.83"	26.0 cm 10.24"	38.5 cm 15.16"	12.0 cm 4.72"
OCCSTD-BU case and back pack strap	103.0 cm 40.55"	56.0 cm 22.05"	14.5 cm 5.71"	27.5 cm 10.83"	26.0 cm 10.24"	38.5 cm 15.16"	12.0 cm 4.72"
OCCSTD-T thinline classic	107.0 cm 42.13"	56.0 cm 22.05"	14.5 cm 5.71"	27.5 cm 10.83"	26.0 cm 10.24"	38.5 cm 15.16"	10.5 cm 4.13"
ELECTRIC	A	B	C	D	E	F	Height
OEGCSTD rectangle	105.0 cm 41.34"	50.0 cm 19.68"	–	–	–	33.0 cm 12.99"	9.0 cm 3.54"
OCCSTD single cut	101.0 cm 39.67"	50.0 cm 19.68"	15.0 cm 5.9"	23.0 cm 9.05"	21.0 cm 8.27"	34.0 cm 13.38"	10.0 cm 3.94"





CASES ECONOMY



OABCSTD

OEBSTD

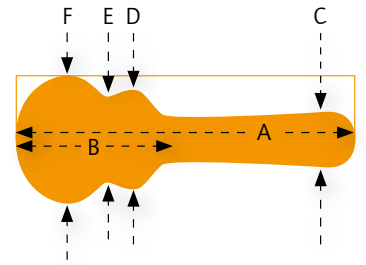

BASS CASE

INNER DIMENSIONS

ACOUSTIC	A	B	C	D	E	F	Height
OABCSTD acoustic bass	127.0 cm 50.0"	58.5 cm 23.03"	16.0 cm 6.3"	32.0 cm 12.6"	29.5 cm 11.61"	43.0 cm 16.93"	13.5 cm 5.31"
ELECTRIC	A	B	C	D	E	F	Height
OEBSTD electric bass	119.0 cm 46.85"	55.5 cm 21.65"	-	-	-	34.5 cm 13.58"	9.0 cm 3.54"



OBJCSTD

OMCSTD-A

OMCSTD-F

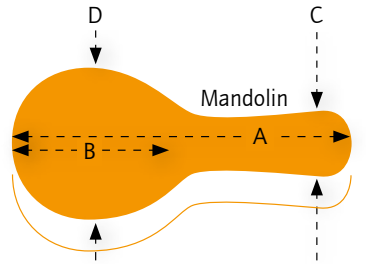
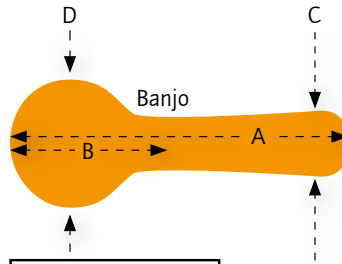

BLUEGRASS CASES

INNER DIMENSIONS

	A	B	C	D	Height
OBJCSTD Banjo regular 5/6 String	103.0 cm 40.55"	44.0 cm 17.32"	14.0 cm 5.51"	34.5 cm 13.58"	12.5 cm 4.92"
OMCSTD-A Mandolin A-style	71.0 cm 27.95"	39.0 cm 15.35"	15.0 cm 5.91"	27.5 cm 10.83"	10.0 cm 3.94"
OMCSTD-F Mandolin F-style	71.0 cm 27.95"	39.0 cm 15.35"	15.0 cm 5.91"	27.5 cm 10.83"	10.0 cm 3.94"



OUCSTD-SO

OUCSTD-CC

OUCSTD-TE

OUCSTD-BA

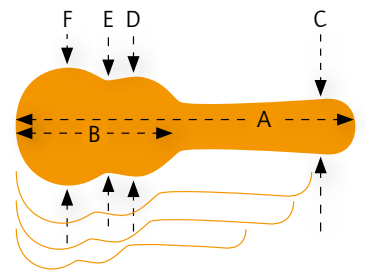

UKULELE CASES

INNER DIMENSIONS

	A	B	C	D	E	F	Height
OUCSTD-SO soprano	55.0 cm 21.65"	29.0 cm 11.42"	12.0 cm 4.72"	14.5 cm 5.71"	14.0 cm 5.51"	17.0 cm 6.69"	8.5 cm 3.35"
OUCSTD-CC concert	66.5 cm 26.18"	32.5 cm 12.8"	13.0 cm 5.12"	14.5 cm 5.71"	14.0 cm 5.51"	19.5 cm 7.68"	9.0 cm 3.54"
OUCSTD-TE tenor	71.0 cm 27.95"	37.0 cm 14.57"	13.5 cm 5.31"	18.5 cm 7.28"	16.5 cm 6.5"	22.0 cm 8.66"	10.0 cm 3.94"
OUCSTD-BA baritone	81.0 cm 31.89"	40.5 cm 15.94"	16.5 cm 6.5"	21.0 cm 8.27"	18.0 cm 7.09"	25.0 cm 9.84"	10.0 cm 3.94"





OCCPRO

OCCPRO-T

CASES PRO

The extraordinary deluxe instrument cases in modern brown croco style vinyl finish. Arched case top, 15 mm padding - covered by "coffee crushed" velvet, built-in hygrometer, generous accessory compartment, combination lock, bronze vintage style hardware and a comfortable soft double pipe handle distinguishes these exclusive cases.

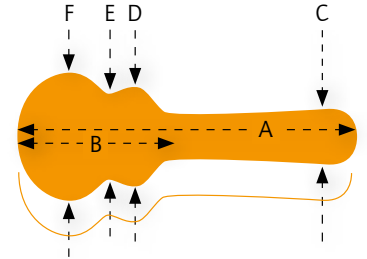

GUITAR CASES

INNER DIMENSIONS

	A	B	C	D	E	F	Height
OCCPRO regular classic	103.0 cm 40.55"	56.0 cm 22.05"	14.5 cm 5.71"	27.5 cm 10.83"	26.0 cm 10.24"	38.5 cm 15.16"	12.0 cm 4.72"
OCCPRO-T thinline classic	107.0 cm 42.13"	56.0 cm 22.05"	14.5 cm 5.71"	27.5 cm 10.83"	26.0 cm 10.24"	38.5 cm 15.16"	10.5 cm 4.13"

CASES BACK PACK STRAPS



ORTEGA BACK PACK STRAP

Designed to carry hard cases like a gig bag.

- Adjustable shoulder straps
- Securely fasten your case with adjustable straps and hard plastic release buckles
- Fits ALL shaped hard cases
- 10 mm soft padding with up to 85 mm wide shoulder pads
- Easy to install and remove - no tools needed!
- Nylon, black

OBPS



ORTEGA BACK PACK STRAP DELUXE

Designed to carry hard cases like a gig bag. The Ortega Back Pack Strap Deluxe features an ergonomic padded back cushion to relax your back while carrying your case.

- Adjustable extra wide shoulder straps
- Ergonomic padded back cushion
- Securely fasten your case with adjustable straps and hard plastic release buckles
- Fits ALL shaped hard cases
- 10 mm soft padding with up to 85 mm wide shoulder pads
- Easy to install and remove - no tools needed
- Nylon, black

OBPS-DLX



STANDS

WOODEN GUITAR/UKULE STANDS



GUITAR
OWGS-1

GUITAR
OWGS-2

UKULELE
OWUS-1

UKULELE
OWUS-2

The perfect stand for home, office and shop. Made from birch, the Ortega guitar stand is as beautiful as it is supportive. Soft and safe "anti-slip" padding for best protection. Assembles in minutes.

OWGS-1/OWUS-1
birch, dark brown

OWGS-2/OWUS-2
birch, natural bright

PORTABLE GUITAR/UKULE STANDS



GUITAR
OPGS-1BK*

UKULELE
OPUS-1BK*

GUITAR
OPGS-1ORBK*

UKULELE
OPUS-1ORBK*

Made with extremely lightweight and strong synthetic material. Fits all sizes of guitars, basses, ukuleles, mandolins & more. Divided body rest for electric or acoustic guitars (OPGS) and easy to fold.

4 STEPS AND YOU'RE DONE!

GUITAR: **OPGS-1BK**
full black
OPGS-1ORBK
Ortega orange/black

UKULELE: **OPUS-1BK**
full black
OPUS-1ORBK
Ortega orange/black

1-2-3-4: FITS YOUR INSTRUMENT!

4-3-2-1: FITS YOUR GIG BAG!

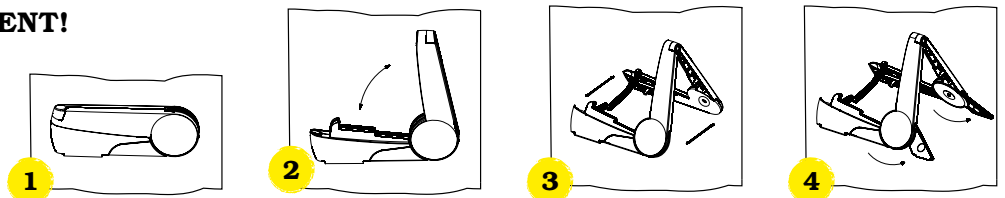

OMS-1BK

MUSIC STAND OMS-1BK

The Ortega portable music stand for the traveling musician or student on the go. Easy to use with 3 seamless tubes for adjusting height, a strong tripod base and a large book tray.

FREE bag included.

- Made of lightweight, non-corrosive aluminum
- Height adjustable from 57 cm (22") to 127 cm (50")
- Book tray: 43.5 cm (17.13") x 22 cm (8.66")

FOOT STOOL

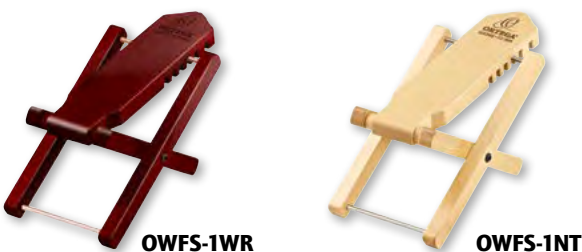

OWFS-1WR

OWFS-1NT

Ortega headstock shaped wooden foot stool

OWFS-1WR
wine red

OWFS-1NT
natural

WALL HANGER

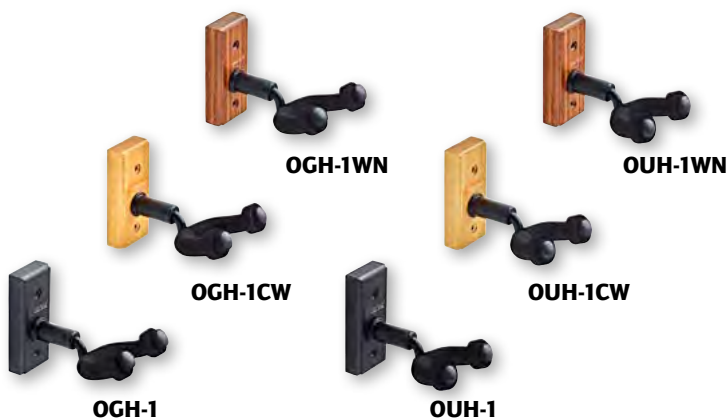

Easy to mount with included screws and drywall anchors. Soft padded cradle support.

Guitar/Bass wall hanger, straight

OGH-1 Wood base, black

OGH-1CW Cherry wood base, natural

OGH-1WN Walnut wood base, natural

Ukulele wall hanger, straight

OUH-1 Wood base, black

OUH-1CW Cherry wood base, natural

OUH-1WN Walnut wood base, natural

ADJUSTABLE WALL HANGER



Easy to mount with included screws and drywall anchors. Soft padded cradle support.

OGHAD-1 models have a boom and are angle adjustable. Now available in two additional wood bases.

OGHAD-1 Wood base, black, adjustable angle

OGHAD-1CW Wood base, adjustable angle, 170 mm/6.69", Cherry wood, natural

OGHAD-1WN Wood base, adjustable angle, 170 mm/6.69", Walnut wood, natural

HOLDER OMUH-BK



Ukulele holder for microphone, guitar and music stands.

Holder easily clips onto stand. Fits all size ukuleles as well as mandolins or other small folk instruments. Extra strong clamp system and soft padded cradle support.

Color: all black

ORTEGA TABLET HOLDER - DELUXE VERSION OTBH-DLX



Tablet holder with gooseneck and incl. clamp.

- Heavy duty, universal tablet holder
- Suitable for almost all tablet computers up to 13" displays
- Strong flexible goose neck
- Freely adjustable/rotatable tablet holder
- Mount to a stand/microphone stand with standard 5/8 thread or with included clamp (up to 35 mm/1.38" diameter)

GUITAR STAND OGS-1BK



Ortega guitar stand, black/orange.

The perfect rest for acoustic guitars, acoustic basses, electric guitars and electric basses.

- Lightweight and durable steel tubing covered with soft black neoprene rubber tubing to protect your instrument. Folds down for easy transport and storage
- Security strap/neck included (do not use with nitrocellulose-finished instruments)



POS



Instruments not included



SW-W120-MA



OSWA-U-AD



OSWA-U-ST



OSWA-G-AD



OSWA-G-ST



OSWA-ACC



Instruments not included



DIS-ORUKE-10

SW-W120-MA Ortega point of sale display modular system, 250 cm (98.43") height, 120 cm (47.24") width. Ortega Slatwall modular system all parts: 1x SW-W120-MA | 2x SW-LT, feet | 1x SW-TF, feet extension (option for freestanding) | 1x SW-OP120/30, Ortega Guitars panel | 2x SW-W-SA240, side cover

OSWA-U-AD Slatwall hook for ukulele, long, adjustable

OSWA-U-ST Slatwall hook for ukulele, short, straight

OSWA-G-AD Slatwall hook for guitar, long, adjustable

OSWA-G-ST Slatwall hook for guitar, short, straight

OSWA-ACC Slatwall hook for accessories

DIS-ORUKE-10 Ortega ukulele display fits 10 ukuleles from soprano to baritone/Ukubass size, 200 cm (78.70") height, 65 cm (25.60") width

DIS-ORTLAMA18 Ortega point of sale ellipse display stand, 230 cm (90.55") height, 60 cm (23.62") width

ODECOFLAG Ortega deco flag, 70 cm (27.56") height, 60 cm (23.62") width

OBS24V2 Bar/stage stool, 61 cm (24")

OBS30V2 Bar/stage stool, 76 cm (30")

ORUG Ortega shop/stage rug, 140 x 80 cm (55" x 32"), anti slip rubber bottom



DIS-ORTLAMA18



ODECOFLAG

OBS24V2
61 cm (24")OBS30V2
76 cm (30")

ORUG 140 x 80 cm (55" x 32")

APPAREL & MERCHANDISE

Ortega Guitars original Apparel & Merchandise available on:

www.ortegaguitars.com/shop



WE VALUE BRAND PARTNERSHIP

Since establishing Ortega guitars in 1994, we've strived to find the best brands in supplying the important parts needed to complete our instruments. We value these relationships with our partners who match the quality and passion that we have for our instruments. Ortega guitars are equipped with the premium strings, hardware and electronics from the best brands.

ORTEGA® MagusUkeGO

FISHMAN®

ORTEGA® MagusUke

SAVAREZ

ORTEGA® MagusUkeBass

Aquila

ORTEGA® MagusPRO/G

ORTEGA® MagusPRO/B

ORTEGA® FISHMAN®

BAND®

ORTEGA GUITARS
CUSTOM MADE STRINGS

D'Addario

All listed trademarks, brandnames and original logos are property of the registered owners.

Ortega Imprint

Additional changes without notice possible. If necessary - dealer/distributor contact is recommended for detailed information.

Not responsible for typographic errors. No part of this brochure may be reprinted, reproduced or included in any online service or in any other form, in whole or in part, without the prior permission of Ortega. Specifications are subject to change without notice.

Content & Direction:

Bastian Krämer & Ortega Guitars team
Germany/USA - ortegaguitars.com

Concept, Design & Realization:

Werner Stubenvoll & zeitstopp team - zeitstopp.com

Photography and Image Processing:

Christian Habermeier, Sebastian Jäger - studio waldeck
Danny Lucenara - ortegaguitars.com

Stock footage: istockphoto.com

Cover photo: artist: Kamil Mueller | photo: Mediaunlimited

© 2020 - Ortega is a registered brand of
Roland Meinel Musikinstrumente GmbH & Co.KG

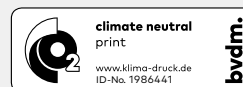

O-CA102012

Printed in Germany

ORTEGA®
GUITARS • EST 1994

Thanks to all musicians around the globe playing Ortega instruments!



GLOBAL HEADQUARTERS

Ortega
Musik-Meinl-Str.1
91468 Gutenstetten
Germany

US HEADQUARTERS

Meinl USA L.C.
Ortega
3427 Ambrose Avenue
Nashville, TN 37207
USA

info@ortegaguitars.com
www.ortegaguitars.com

ORT-CATALOG20



8 42960 14398 0